

Scan 64 - series



Congratulations on your new Scan wood-burning stove

You have purchased a product by one of Europe's leading manufacturer's of wood-burning stoves, and we are sure that you will have years of pleasure with your purchase. To make the best possible use of your stove, it is important that you follow our advice and instructions.

Please read this Assembly- and instructions manual before you start to assemble your stove.

Table of contents

Technical data	3
Installation	
Safety	
Technical data and dimensions	
Dimension sketch	
Type plate	
Product registration number	
Additional accessories	
Service box	
Loose parts	
Assembly	8
Remove packaging	
Positioning your wood-burning stove	
Distance to furniture	
Distance to flammable materials, shown with insulated flue pipe	
Distance to flammable materials, shown with un-insulated flue pipe	
Distance to firewall	
Height adjustment of stove	
Load bearing foundation	
Floor plate	
Existing chimney and pre-fabricated element chimney	
Connection between stove and steel chimney	
Requirements for chimney	
Connection with 90° elbow pipe	
Connecting piece / top outlet	
Connecting piece / rear outlet	
Fitting the soapstone sides	
Fresh air intake	
Closed combustion system	
Indicator for control of air supply	
Scan 64 open plinth	
Scan 64 with right-hung wood compartment door	
Scan 64 with right-hung door	
Accessories	27
Fitting the soapstone top	
Handle	
Instruction for use	29
CB technique	
Primary air	
Secondary air	
Baffle plates	
Ash drawer	
Handle for riddling grate	
Instructions for heating	30
Lighting	
Handling fuel	
Maintenance	32
Troubleshooting	34

Installation

The house owner is responsible for ensuring that all necessary national and local safety measures are observed during installation and fitting and also responsible for observing the fitting and operating instructions detailed in this manual.

When you install any kind of fireplace or stove, you must inform the local authorities. You are also responsible for calling in a chimney sweep to inspect and authorize the installation.

To ensure best-possible functionality and safety for your installation, we advise you to call a professional fitter. Our Scan Dealer will be able to recommend a qualified fitter in your area. For information on Scan Dealers, please go to www.scan.dk.

Safety

Any changes made to the product by the dealer, installer or user could result in the product and safety functions not functioning as intended. The same applies to the fitting of accessories or extra equipment not supplied by Scan A/S. This could also be the case if parts that are necessary for the operation and safety of the stove are dismantled or removed.

The Scan 64 - series range comprises:

Scan 64-1: Stove with steel sides

Scan 64-2: Stove with steel sides and side windows

Scan 64-3: Stove with soapstone sides

Scan 64-4: Stove with soapstone sides and side windows

Scan 64-5: Stove with aluminium sides

Scan 64-6: Stove with aluminium sides and side windows

Scan 64-1



Scan 64-2



Scan 64-3



Scan 64-4



Scan 64-5



Scan 64-6



Technical data and dimensions

Materials: Steel plate, cast iron, galvanised sheet, vermicolite

Surface treatment: Senotherm

Max. wood length: 30 cm

Weight Scan 64-1 and Scan 64-2: ca. 123 kg

Weight Scan 64-3: ca. 180 kg

Weight Scan 64-4: ca. 168 kg

Weight Scan 64-5 and Scan 64-6: ca. 117 kg

Connecting piece internal diameter: 144 mm

Connecting piece external diameter: 148 mm

Approval type: Intermittent fuelling

Intermittent fuelling means normal use of a woodstove. In other words, you should let the fire die down until only the embers are left, before refuelling.

The Scan 64 - series was build in compliance with the homologized product type specified in the Assembly- and Instructions Manual provided with the product.

The EC declaration of conformity is available from www.scan.dk

Test in compliance with EN 13240

Scan 64-1, Scan 64-3 and Scan 64-5	Technical data	Unit
CO Emission at 13% O ₂	0,08	%
CO Emission at 13% O ₂	975	mg/Nm ³
Dust @ 13% O ₂	< 20	mg/Nm ³
No _x @ 13% O ₂	104	mg/Nm ³
Efficiency	82	%
Nominel output	6	kW
Chimney temperature EN 13240		°C
Temperature in connecting piece	300	°C
Amount of smoke	5	g/sek
Sub-pressure EN 13240	12	Pa
Recommended sub-pressure in connecting piece	15 - 18	Pa
Required combustion air supply	13,3	Nm ³ /h
Fuel		Wood
Fuel consumption	2	kg/h
Amount of fuel	1,5	kg

Scan 64-2, Scan 64-4 and Scan 64-6	Technical data	Unit
CO Emission at 13% O ₂	0,1	%
CO Emission at 13% O ₂	1213	mg/Nm ³
Dust @ 13% O ₂	< 20	mg/Nm ³
No _x @ 13% O ₂	117	mg/Nm ³
Efficiency	79	%
Nominel output	6	kW
Chimney temperature EN 13240		°C
Temperature in connecting piece	305	°C
Amount of smoke	6	g/sek
Sub-pressure EN 13240	12	Pa
Recommended sub-pressure in connecting piece	15 - 18	Pa
Required combustion air supply	12,5	Nm ³ /h
Fuel		Wood
Fuel consumption	2	kg/h
Amount of fuel	1,5	kg

Dimension sketch

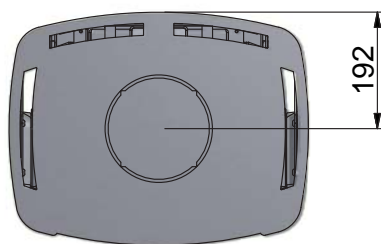
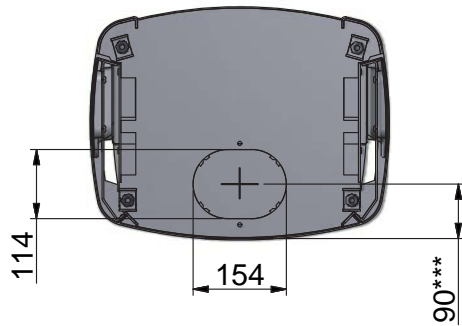

- * Centre rear outlet
- ** Height to the beginning of the connecting piece at top outlet
- *** Centre of fresh air intake bottom

Type plates

All Scan wood-burning stoves are fitted with a type plate, that specifies the approval standards and the distance to flammable materials. The type plate is located at the back of the stove.

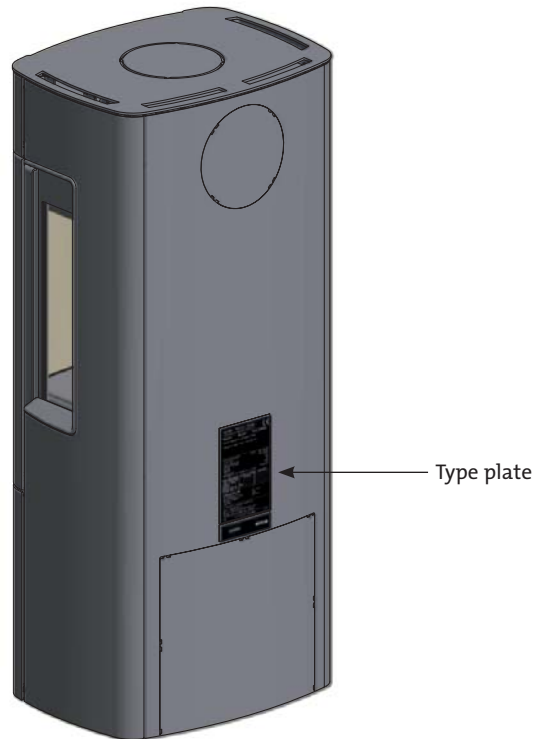

Scan 64-1, Scan 64-3 & Scan 64-5 (Without side windows)

Scan 64-1 - Scan 64-3 - Scan 64-5				CE	
Freestanding room heater fired by solid fuel					
Standard:		EN 13240	EC no. 90064600		
Minimum distance to combustibile materials					
Side: 350 mm - Back: 150 mm - Front: 1000 mm					
DIBt Zulassungsnummer:					
CO emission at 13% O ₂ :		0,08%	975 mg/Nm ³		
Dust at 13% O ₂ :			< 20 mg/Nm ³		
Flue gas temperature:			300°C		
Nominal heat output:			6 kW		
Efficiency:			82%		
Fuel type:			Wood		
Operation type:			Intermittent		
The appliance can be operated in a shared flue.					
Country	Classification	Certificate/Standard	Approved by		
EUR	Intermittent	EN 13240	RWE Power AG		
Norway	Klasse 2	300-ELAB-1528-NS	Teknologisk Institut		
Austria			RWE Power AG		
Schweiz	LRV 11	VKF	RWE Power AG		
Germany	BStV	1 FSPS-Wa 2087-EN	RWE Power AG		
Angaben für Österreich					
Wärmeleistungsbereich:					
Brennstoffwärmeleistung:					
Zulässige Brennstoffe:		Scheitholz			
Prüfbericht:					
Follow assembly- and instructions manual.					
Use only recommended fuels.					
Montage- und Bedienungsanleitung beachten.					
Verwenden Sie nur empfohlene Brennstoffe.					
1000	Scan A/S DK 5492 Vissenbjerg		11-2011		

Scan 64-2, Scan 64-4, & Scan 64-6 (With side windows)

Scan 64-2 - Scan 64-4 - Scan 64-6				CE	
Freestanding room heater fired by solid fuel					
Standard:		EN 13240	EC no. 90064601		
Minimum distance to combustibile materials					
Side: 500 mm - Back: 150 mm - Front: 1000 mm					
DIBt Zulassungsnummer:					
CO emission at 13% O ₂ :		0,10%	1213 mg/Nm ³		
Dust at 13% O ₂ :			< 20 mg/Nm ³		
Flue gas temperature:			305°C		
Nominal heat output:			6 kW		
Efficiency:			79%		
Fuel type:			Wood		
Operation type:			Intermittent		
The appliance can be operated in a shared flue.					
Country	Classification	Certificate/Standard	Approved by		
EUR	Intermittent	EN 13240	RWE Power AG		
Norway	Klasse 2	300-ELAB-1528-NS	Teknologisk Institut		
Austria			RWE Power AG		
Schweiz	LRV 11	VKF	RWE Power AG		
Germany	BStV	1 FSPS-Wa 2087-EN	RWE Power AG		
Angaben für Österreich					
Wärmeleistungsbereich:					
Brennstoffwärmeleistung:					
Zulässige Brennstoffe:		Scheitholz			
Prüfbericht:					
Follow assembly- and instructions manual.					
Use only recommended fuels.					
Montage- und Bedienungsanleitung beachten.					
Verwenden Sie nur empfohlene Brennstoffe.					
1000	Scan A/S DK 5492 Vissenbjerg		08-2011		

Product registration number

All wood-burning stoves are provided with a product registration number.

The product registration number is located at the back of the stove.

Please make a note of this number below as you will always have to state it if you contact your dealer or Scan A/S.



Additional accessories

- Small shaped floor plate in glass or steel
- Large shaped floor plate in glass or steel
- Soapstone top plate for stove with rear outlet
- Soapstone top plate for stove with top outlet

Service box

The service box contains the following:

- Fitting for connecting piece (not used for this Scan model)
- Seal
- Safety fitting (not used for this Scan model)
- Plastic plugs for transport safety hole at the bottom of the stove
- Various tools
- Glove
- Fire starters for first lighting

Loose parts

Parts for use on right-hung door are supplied fastened to the pallet.

Other loose parts are located in the stove's ash drawer.

Scan 64, all types:

- 4 pcs. screws for fastening the connecting piece
- 1 pcs. indicator for control of air supply
- 4 pcs. teflon bushing for right-facing door hinge

Scan 64-3 and Scan 64-4:

- 10 pcs. screws for soapstone sides
- 10 pcs. distance bushings for soap stone
- 4,5 m gasket

Remove packaging

Check that the stove is not damaged before installing it.

Scan 64 is supplied attached to a wooden pallet. Remove the two screws from the wood compartment store, as illustrated below, and lift the stove off the wooden pallet.

Scan 64-5 and Scan 64-6:

We recommend that you leave the protective film on the side plates until the fitting is complete.

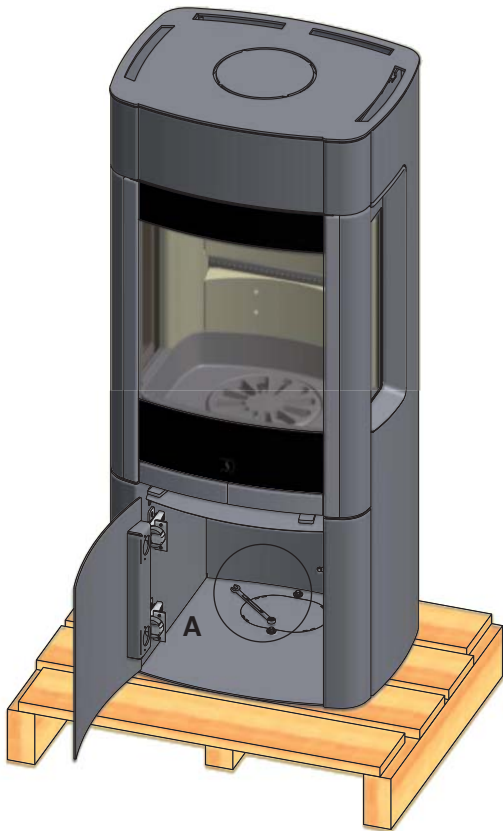

Remove the screws that securing the stove to the pallet.

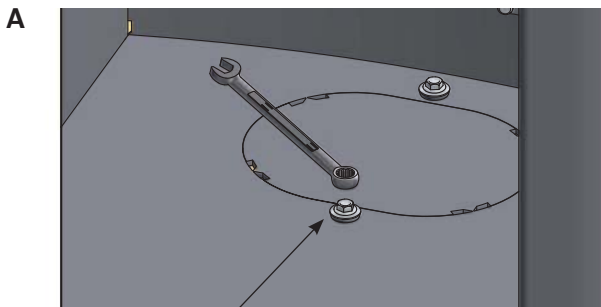

Screws to be removed

Fit the plastic plugs from the service box into the transport protection holes.

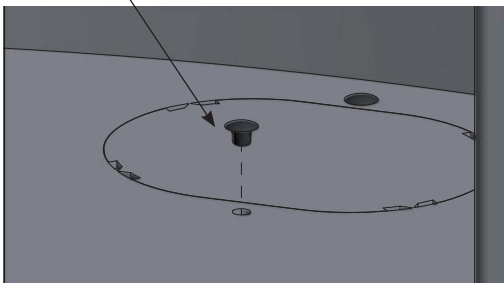

Remove the protection between the baffle plates, before taking the stove into use!

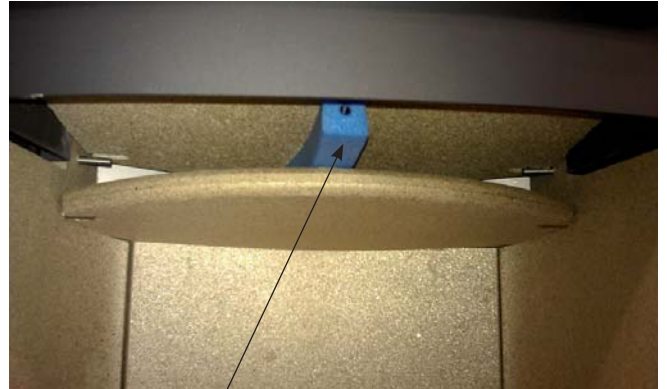

Protection for baffle plates

Put back the upper plate on the pins, as the protection pushes the plate upwards.



Pin for baffle plate

Installation:

Positioning your wood-burning stove

The wood-burning stove must be set up so that the stove itself, the flue pipe, and the chimney can all be cleaned.

Distance to furniture: 1000 mm

But please check to avoid furniture or other furnishings being dried out due to being too close to the stove.

All national and local requirements concerning safety distances for wood burning stoves must be respected.

If you connect the stove to a steel chimney, the safety distances of the steel chimney must also be respected.

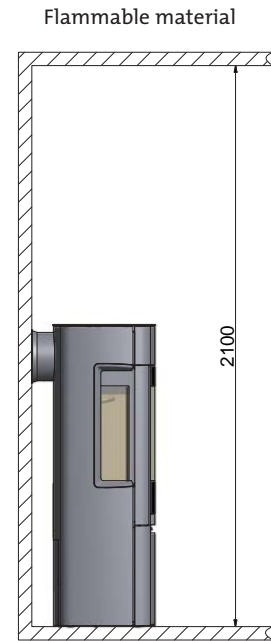

Distance to flammable materials, shown with insulated flue pipe

The distances presuppose the use of an insulated flue pipe with min. 30 insulation all the way to the stove.

Scan 64-1, Scan 64-3 and Scan 64-5 (without side windows)

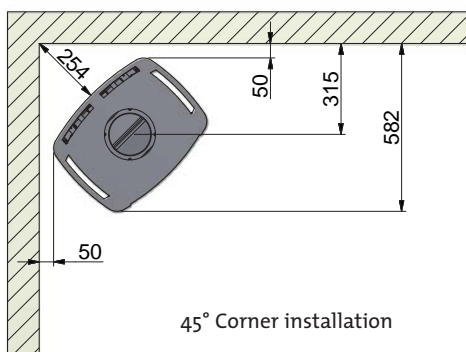
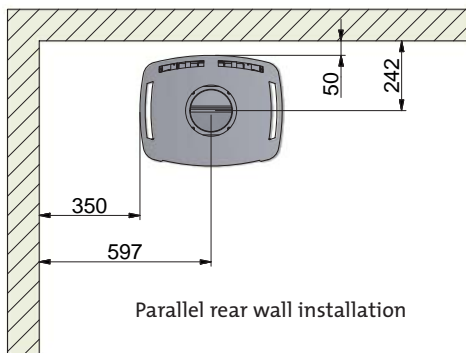

Scan 64-2, Scan 64-4 and Scan 64-6 (with side windows)

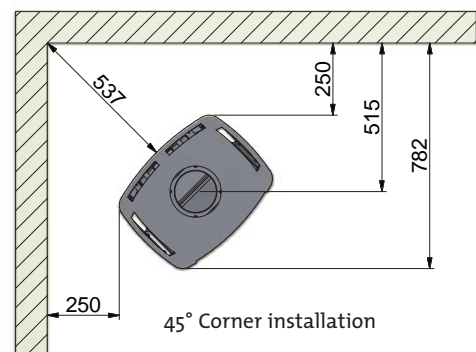
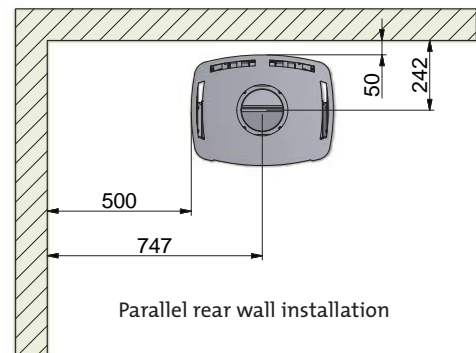

Distance to flammable materials, shown with un-insulated flue pipe

Scan 64-1, Scan 64-3 and Scan 64-5 (without side windows)

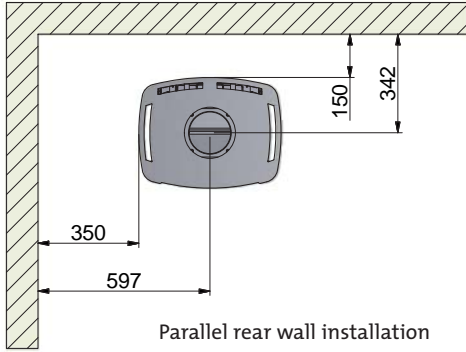

Parallel rear wall installation

Scan 64-2, Scan 64-4 and Scan 64-6 (with side windows)

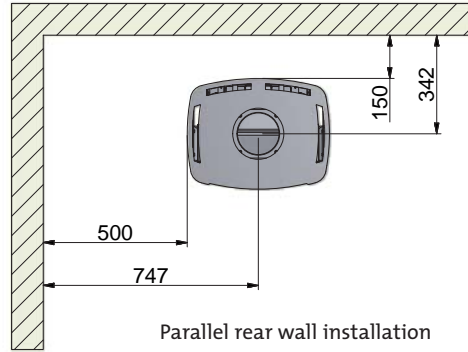

Parallel rear wall installation

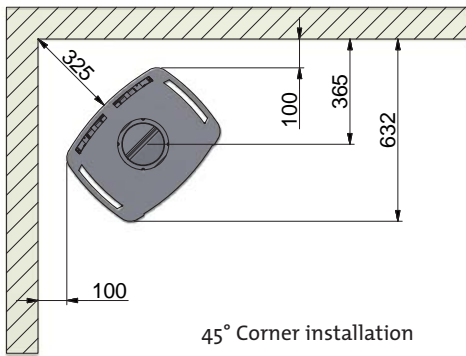

45° Corner installation

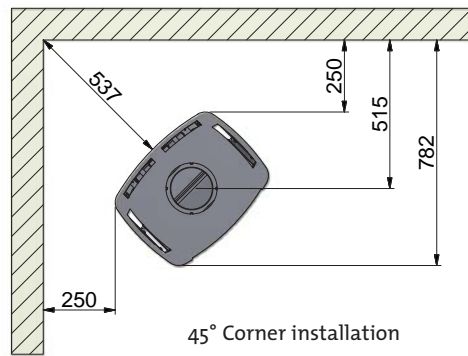

45° Corner installation

Distance to firewall

110 mm brick or other material with a corresponding insulation ability.

The distances presuppose the use of an insulated flue pipe with min. 30 insulation all the way to the stove.

Scan 64-1, Scan 64-3 and Scan 64-5 (without side windows)

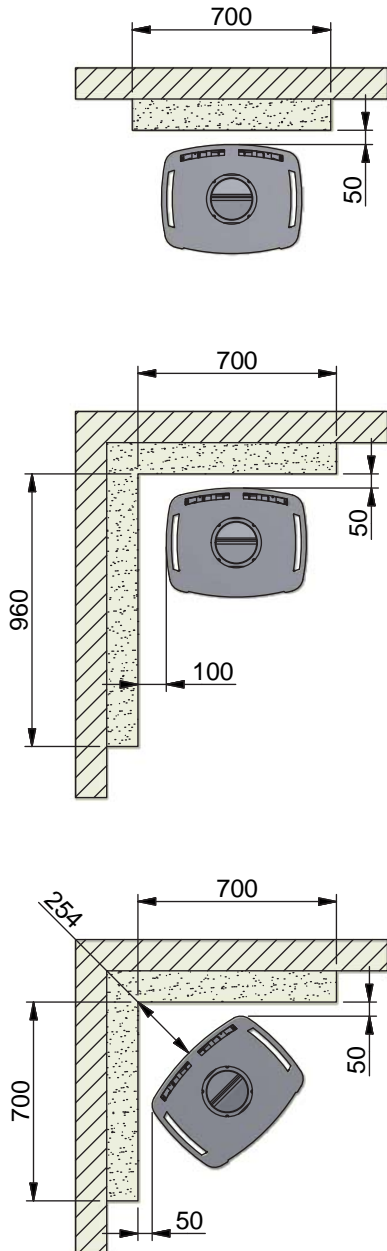

Scan 64-2, Scan 64-4 and Scan 64-6 (with side windows)

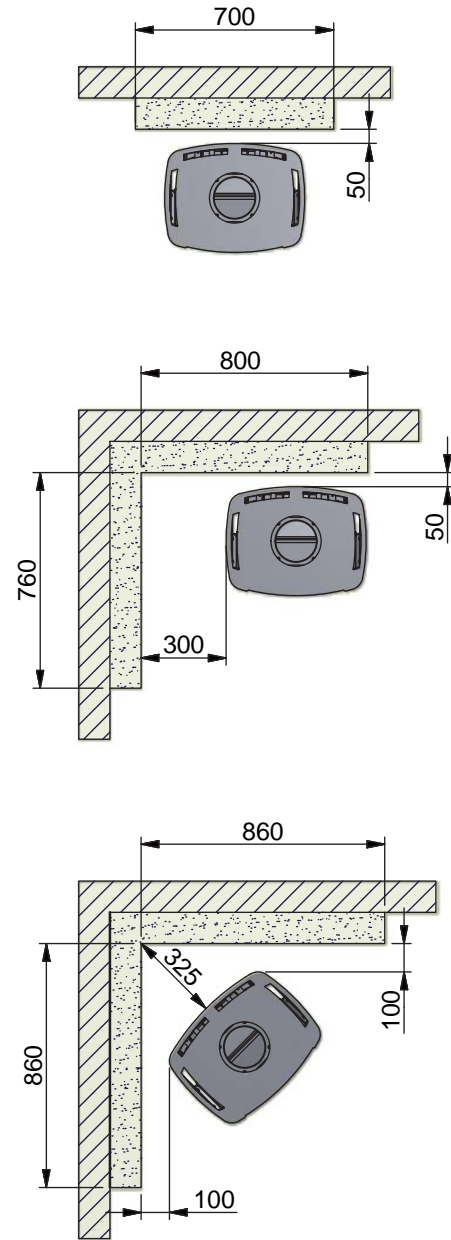

Height adjustment of stove

The Scan 64 has four adjustment screws under the stove. Use the adjustment screws to get the stove to stand straight and level.

Tilt the wood-burning stove and adjust the adjustment screws.

If you are using a shaped floor plate, you should adjust the stove upwards to allow the plate to be inserted under the front of the stove.

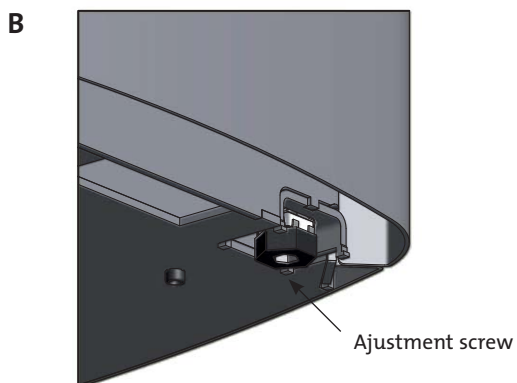

Load bearing underlay

All of the products in our portfolio are classified as light-duty fireplaces; in most cases, there is no need to reinforce the floor, so that you can typically use the normal floor.

However, you should make sure that the load bearing underlay can bear the weight of the wood-burning stove and that of the chimney.

Floor plate

If you are setting up the stove on a flammable floor, observe national and local regulations on the size of the non-flammable underlay that covers the floor around the stove.

Your local Scan dealer can advise you on regulations concerning flammable materials in the vicinity of your stove.

The idea behind the floor plate is that it protects the floor and flammable material against sparks.

The floor plate can be made of steel or glass, and the stove can be set up on brick, natural stone or similar materials.

This Scan wood-burning stove has an integrated floor plate, and can thus be set up on any flammable material without a protective underlay.

Small shaped floor plate in glass or steel.

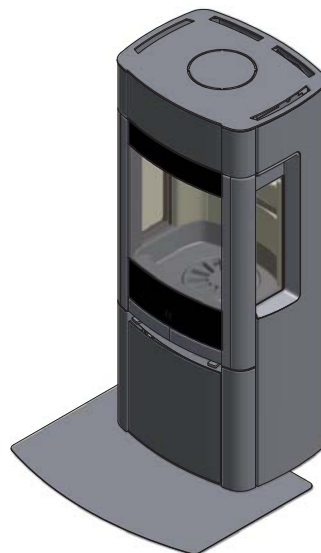

Large shaped floor plate in glass or steel

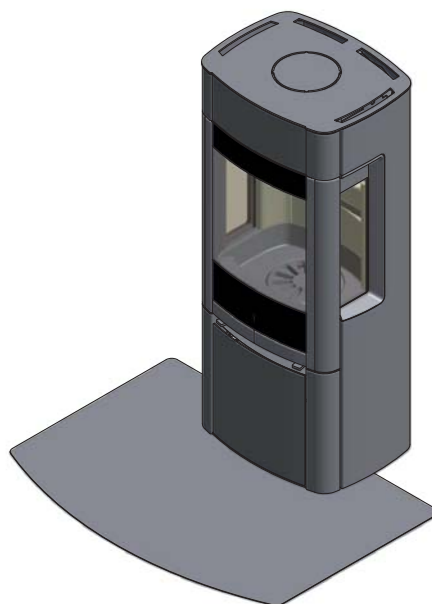

Existing chimney and pre-fabricated element chimney

If you intend to connect your stove to an existing chimney, it makes sense to contact an authorised Scan dealer, or a local chimney sweep for advice. These experts will also let you know if your flue needs renovating.

When connecting a pre-fabricated element chimney, follow the manufacturer's connection instructions for the relevant chimney type.

Connection between stove and steel chimney

Your Scan dealer, or local chimney sweep, can advise you on choosing a make and type of steel chimney. This ensures that the chimney will match your wood-burning stove. As a general rule, the length of the flue should not be less than 3,5 m measured from the top of the wood-burning stove.

Some weather or installation conditions might require another length.

Choosing the wrong length or diameter of steel chimney could impair functionality.

Always observe the chimney vendor's instructions precisely.

Requirements for chimney

The chimney must be labelled T400 and G for soot testing.

Connection with 90° elbow pipe

If you intend to use an elbow pipe with the Scan 64, we recommend the use of a curved elbow pipe to improve the draft.

If you are connecting your stove using a sharp elbow bend, the cleanout door should be in the vertical section, such that the horizontal part can be cleaned through it.



Connecting piece / top outlet

The stove is prepared from the factory for top outlet.

The connecting piece is placed loosely in the top outlet of the stove. The gasket for the connecting piece is in the service box. The screws for fastening the connecting piece are in the stove's ash drawer.

Lift the top plate and connecting piece off the stove.



Mount the ceramic gasket on the connecting piece

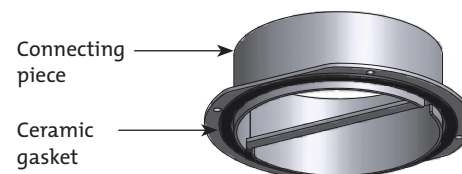

Removing the cover plate from the top plate

To remove the cover plate from the top plate, you can use a slotted screwdriver as illustrated below. Tilt the screwdriver downwards, and the cover plate will come loose.

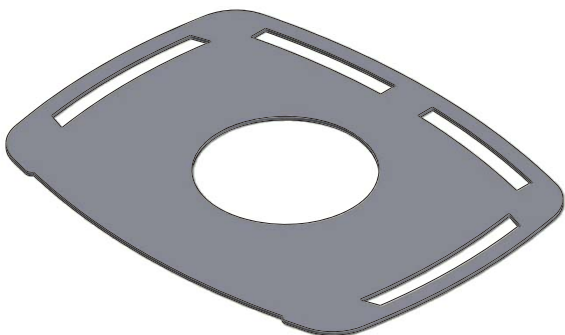
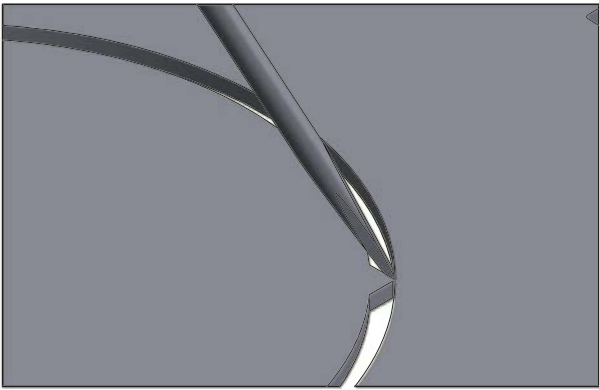
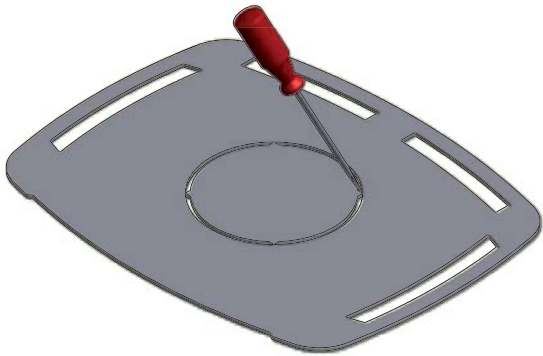

Fasten the connecting piece with screws from the ash drawer and replace the top plate.

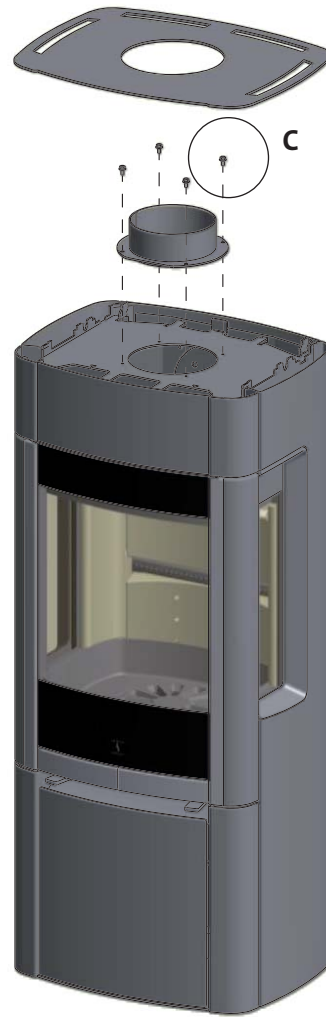

4 pcs. M5x10 mm screw

Connection piece / rear outlet

The stove is prepared from the factory for top outlet.

The connecting piece is placed loosely in the top outlet of the stove.
The gasket for the connecting piece is in the service box.
The screws for fastening the connecting piece are in the stove's ash drawer.

Lift the top plate and connecting piece off the stove.



Mount the ceramic gasket on the connecting piece

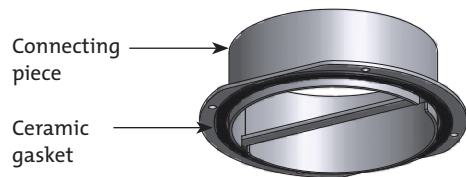

Cut off the cover plate from the rear plate with cutting pliers at the fastening points.

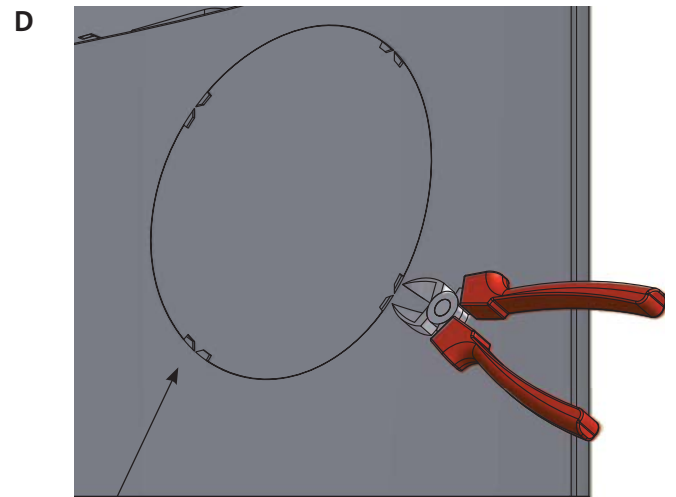

Fastening points

Bend the dowels (E) for the rear plate to the side so the rear plate can be lifted off.



Lift off the rear plate.



E

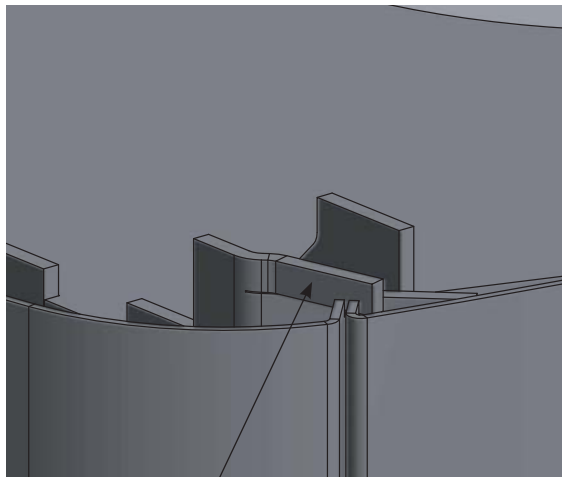

Dowel

Cut off the cover plate from the heat shield with cutting pliers at the fastening points.

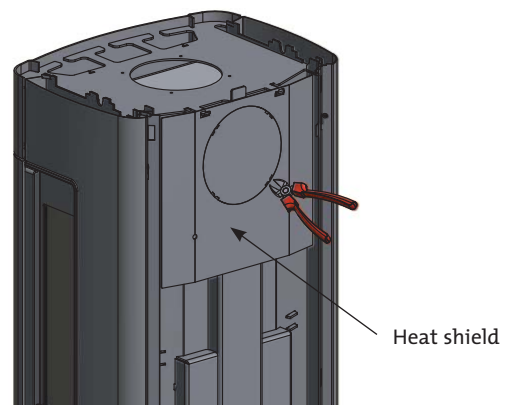

Heat shield

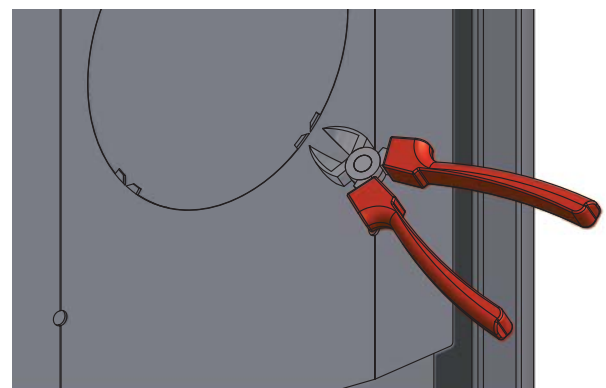

Lift off the heat shield and remove the cover.

The cover is to be used later as a gasket and lid at the top of the flue outlet.

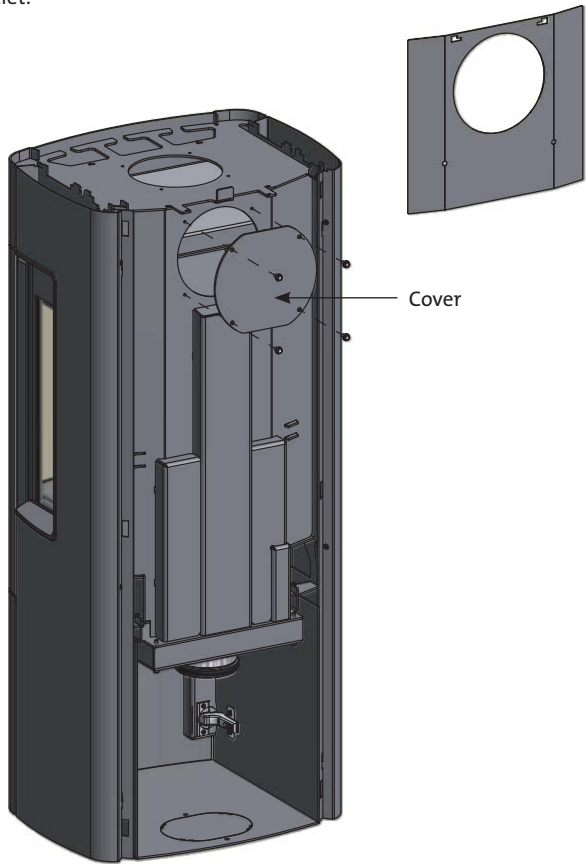

Fit the cover in the top outlet and tighten it.

Replace the top plate.

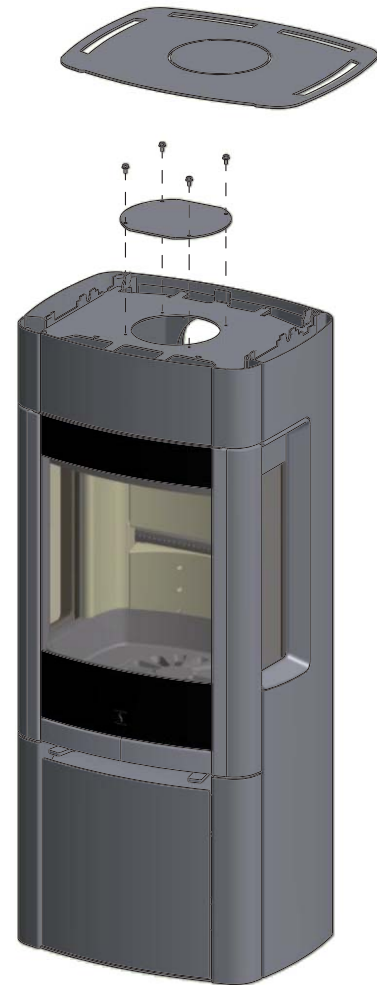

Fit the connecting piece with the four screws found in the stove's ash drawer. Hook and fasten the heat shield and rear plate onto the stove.

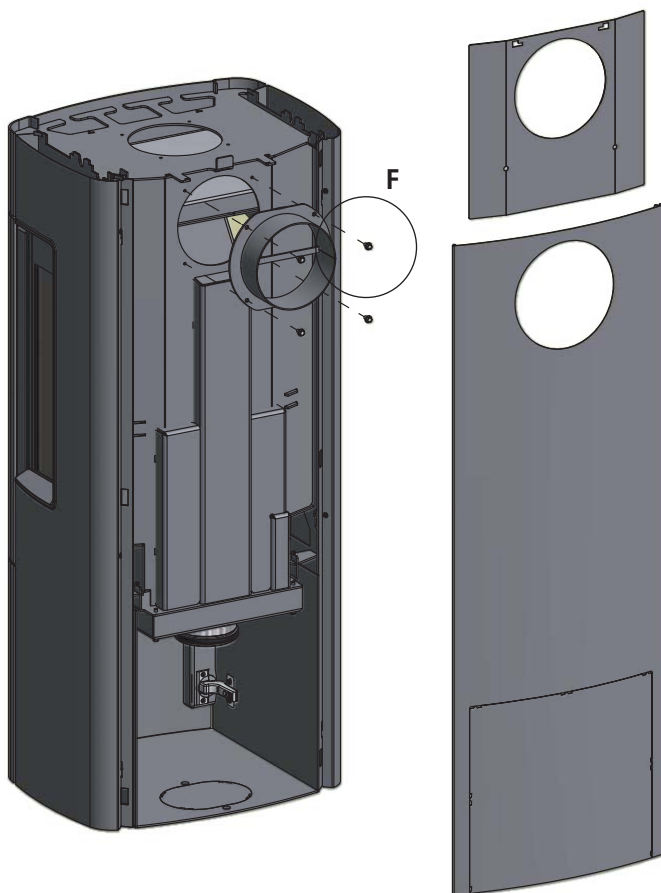

F



4 pcs. M5x10 mm screw

Fitting the soapstone sides

Scan 64-3 and Scan 64-4 are delivered with loose soap stone plates for mounting on the sides of the stove.

Soap stone is a natural material, wherefore there might be differences in structure and form.

Each soap stone is to be mounted with distance bushings and screws (pos. G). These are delivered together with the stove. Use a Torx screwdriver for tightening the screws. You are not to use any electrical tools, as this might tighten the screws too much, resulting in the soap stones breaking.

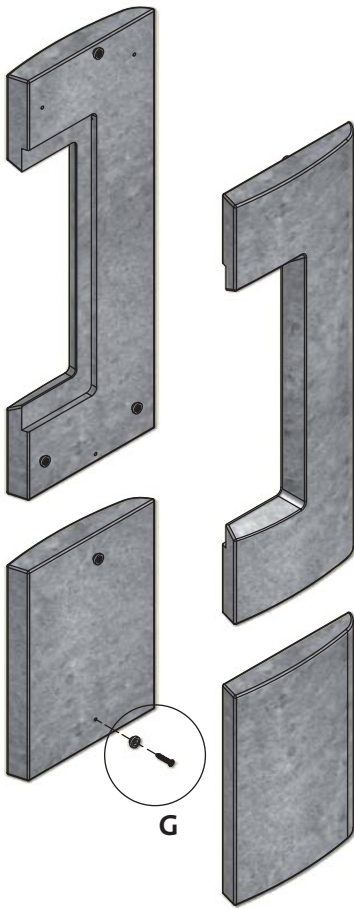

G



10 distance bushings for soap stone



10 screws 6 x 30 mm for soap stone

The delivered gasket (4,5 m) should be cut in appropriate lengths and stuck onto the sides of the stove as shown below.

Scan 63-3 (without side windows)

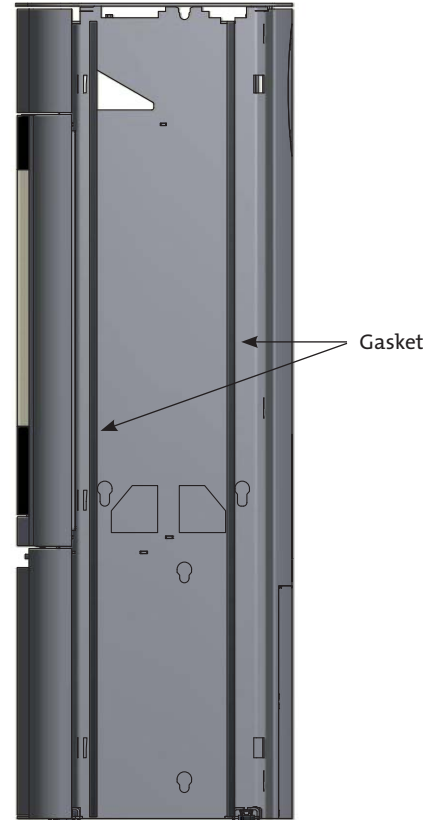

Scan 63-4 (with side windows)

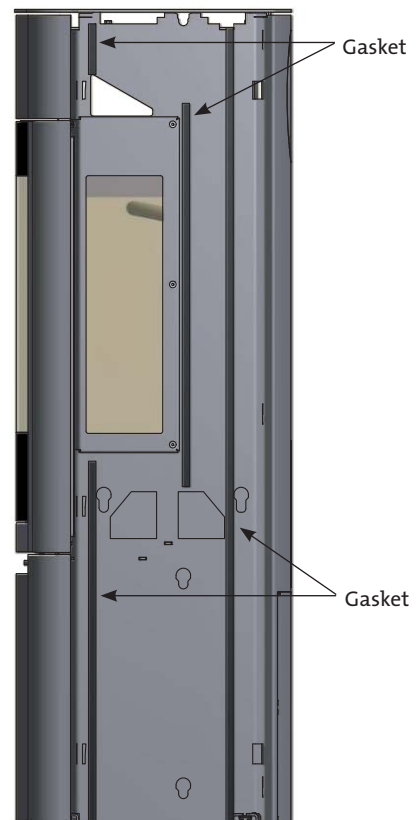

Hook the soapstone sides onto the stove.

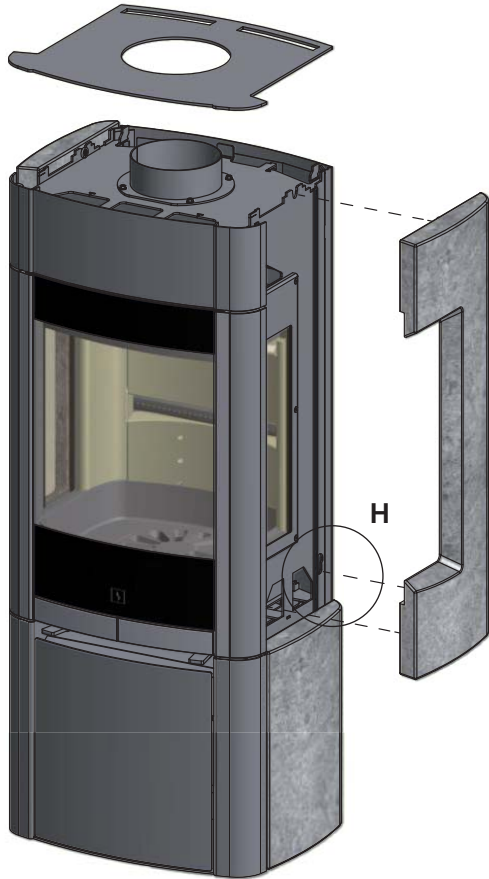

H

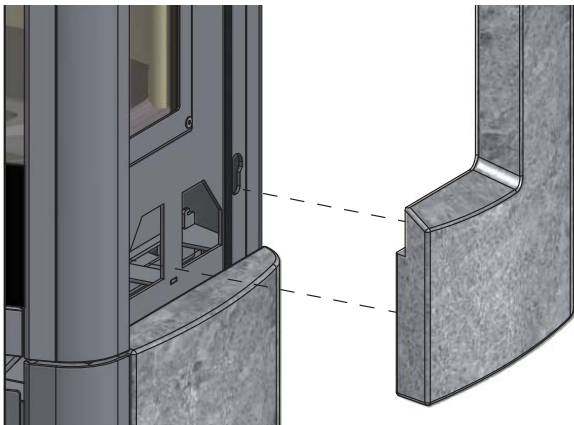

Fresh air intake

In a well-insulated house, the air used up by the burning process has to be replaced. This particularly applies to houses with mechanical ventilation. There are different ways of making sure that an air exchange takes place. The most important thing is to ensure that there is a supply of air to the room where the wood stove is located. The external wall vent must be located as close to the wood stove as possible, and you must be able to close it when you are not using the wood stove.

National and local building regulations must be followed with regard to the connection of fresh-air intake.

Closed combustion system

You should use the closed combustion system for the wood-burning stove if you live in a newly-built, airtight home. Outside air for combustion is connected through a ventilation pipe via the wall or floor.

It must not be possible to shut off the ventilation pipe with a valve

- Minimum $\text{Ø}100$ mm ventilation pipe, maximum length: 6 m with a maximum of one bend

Remove the cover plate at the back of the stove or the cover plate at the bottom of the wood compartment store, as shown on page 15. Connect outside air to the connection piece underneath the combustion chamber.

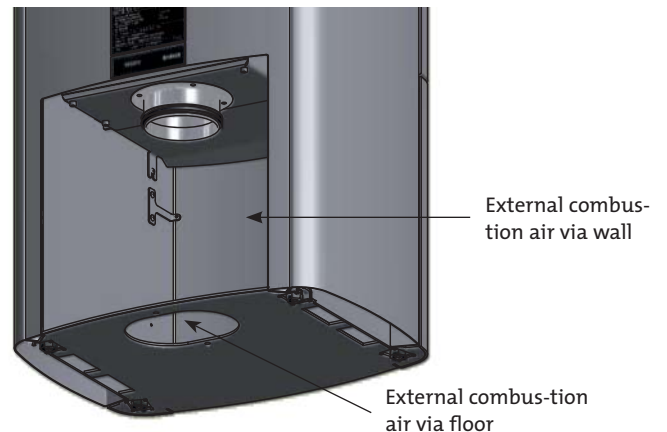
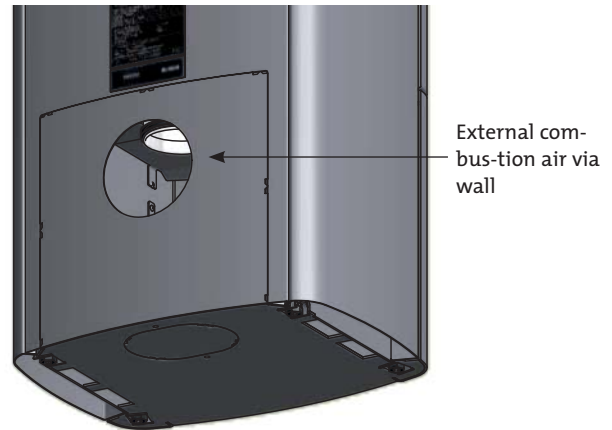

Indicator for control of air supply

The indicator for control of air supply is provided loose and comes in the stove's ash drawer. Fit the indicator to the wood compartment door as shown below. If you choose to remove the stove's wood compartment door, you can fit the indicator onto the handles.

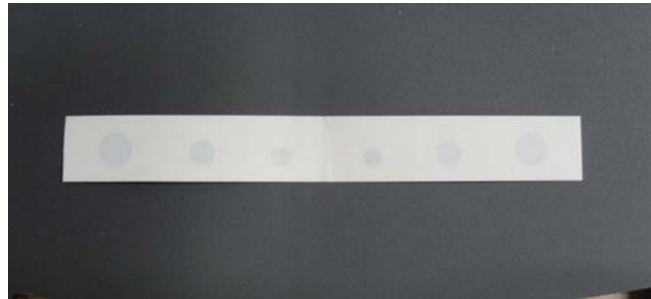

Divide the indicator in the middle and carefully remove the film.



Fit to the stove's wood compartment door as shown below.



Remove the tape carefully.



Scan 64 with open plinth

If you want your Scan 64 with open plinth, remove the wood compartment door and its stop as well as the large cover plate at the back of the stove (see page 15).



Scan 64 with right-hung wood compartment door

If you want your Scan 64 with a right-hung wood compartment door, move the bracket and the door stop in the wood compartment store, and then turn round and fasten the door.



Scan 64 with right-hung door

If you want your Scan 64 with a right-hung door, remove the door and the supplied hinge clamp and then fit the rail for the closing mechanism.



Dismount the spring, loosen the pinto screw, dismount the rivet and lift off the door.

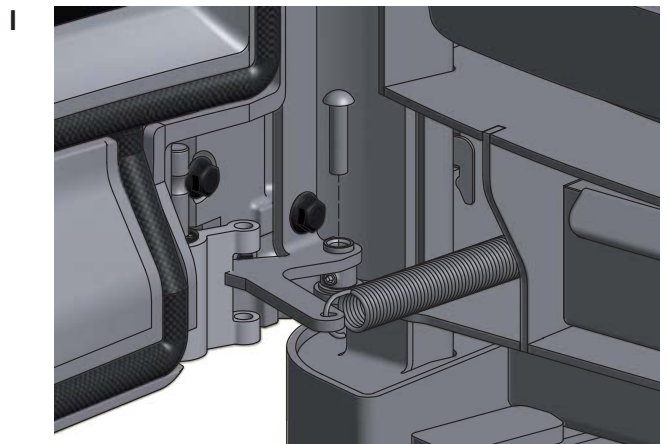



Tools you can use

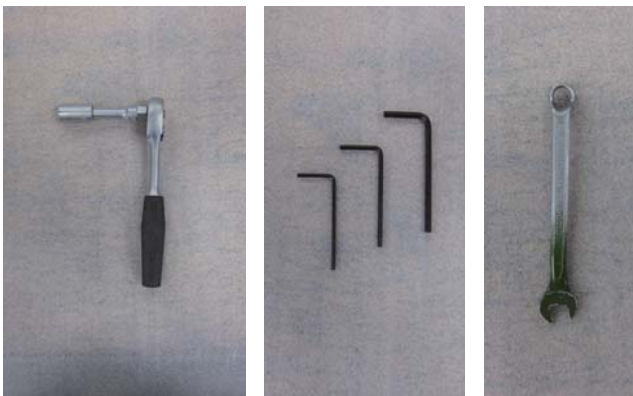

Hinge clamp for right-hung door



Rail for closing mechanism for right-hung door facing right



Remove the pointed screw M5x5 (1)



Screw the pointed screw M5x5 into the hinge clamp for the right-hung door.

Remove the screws (2) in the hinge clamp and lift the clamp off the door.

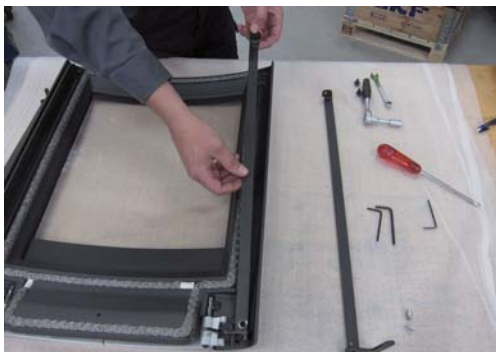

Lift the closing mechanism axle and rail off the door once the Allen screws (3) have been removed.



Mount the two teflon bushings (delivered in the ash drawer) in the rail for closing mechanism for right-hung door.



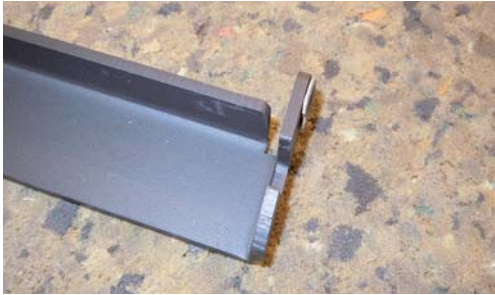

Fit the closing mechanism axle into the closing rail for the right-hung door, fit the parts onto the door and fasten with Allen screws.

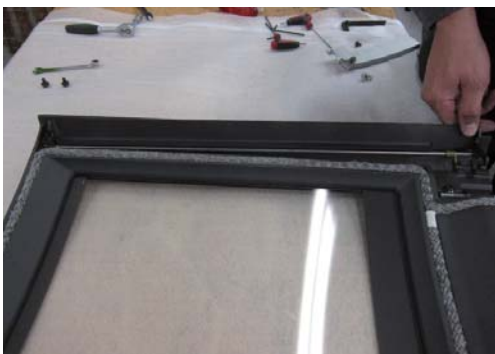

Correctly fitted spring.

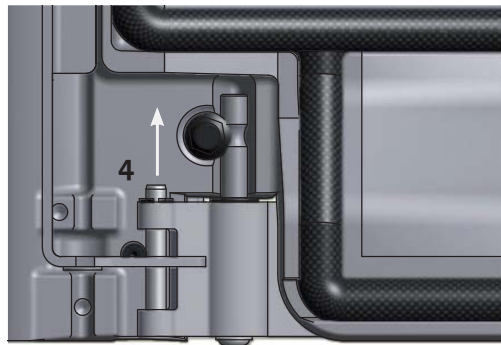

Pull the left handle axle in the direction of the arrow and remove it.

Remove the screw from the right handle.



Remove the handle.



Move the handle axle to the right handle and fasten it.



Fasten the hinge clamp.



Mount the two teflon bushings for right-hand door.

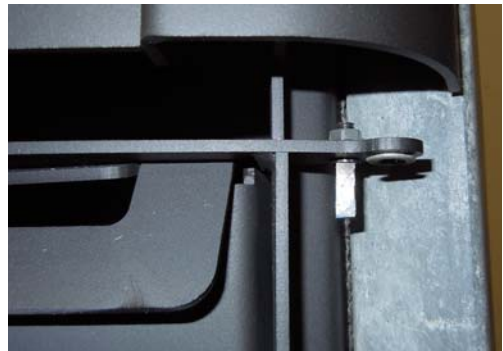

Mount the spring and the door on the stove again.

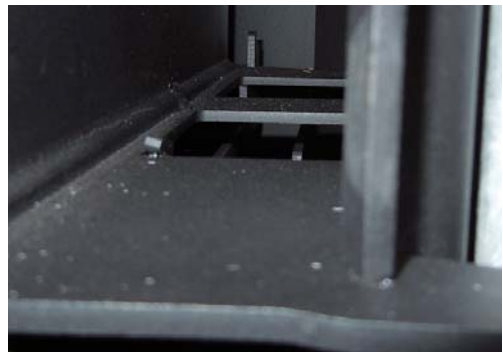

Fitting the soapstone top

You can buy a soapstone top as an accessory. Place the soapstone top on the steel top plate.

Fitting the soapstone top



Handle

Black handles are available as an option. Mount the handles on the stove as shown below.

1



2



3

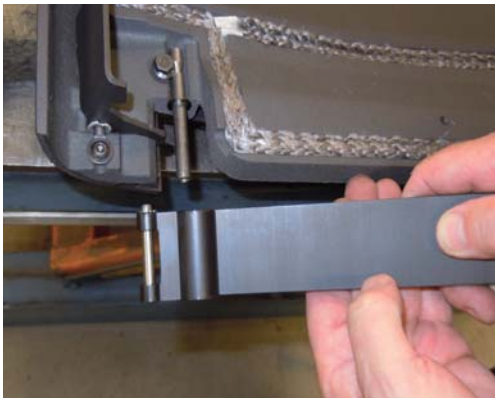

4

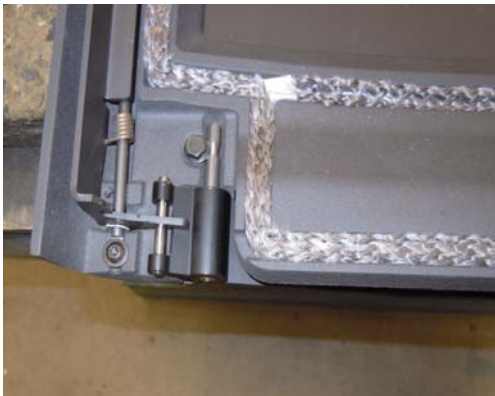

Screws to be dismantled (5+6)

5



6

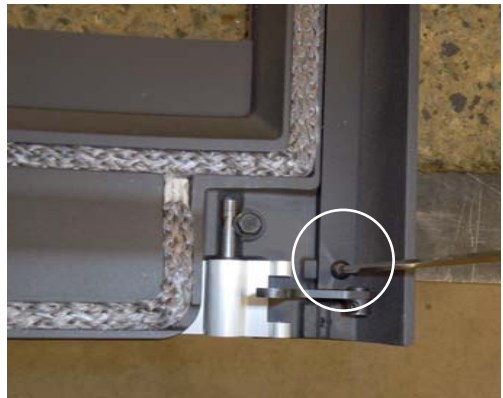

7



8



CB-technique (Clean Burning)

The wood-burning stove is equipped with CB technology. In order to ensure an optimal combustion of released gases under the incineration process, air will pass through a specially developed canal system. The heated air is led into the combustion chamber through the small holes at the rear of the burn chamber. This airflow is driven by the combustion rate and thus cannot be regulated.

Primary air

The primary air regulation mechanism is used for lighting the fire, or to boost the burning process when you put wood on. The primary air vent can be 0 - 30% open if you use hard wood fuel such as oak and beech. You can close the primary air vent if you use soft wood such as birch or pine for fuel.

Settings for normal load: 0 - 30%

Secondary air

Secondary air is pre-heated and fed indirectly to the fire. At the same time, the secondary airflow cleans the glass pane to avoid soot build-up. If you over-restrict the secondary airflow, soot can build up on the glass pane. The secondary airflow determines the heat output from your wood stove.

Settings for normal load: 50 - 70%

Baffle plates

The baffle plates are located in the upper part of the combustion chamber. The plates hold back smoke, making sure it stays inside the combustion chamber for a longer time before escaping through the chimney. This reduces the smoke gas temperature as the gases have more time to dissipate heat to the wood-burning stove. The baffle plates must be removed for sweeping; see „Maintaining your wood-burning stove“. Note that the baffle plates are made of porous, ceramic material, and can break. Exercise care when working. The baffle plates are subject to wear and tear, and are not covered by the warranty.

Ash drawer

Open the glass door to access the ash pan which is located below the combustion chamber.

Keep the ash pan closed at all times when the wood stove is lit.

The ash drawer must not be overfilled and must therefore be emptied at regular intervals.

Handle for riddling grate

Your wood stove is fitted with a riddling grate which empties the ash from the combustion chamber into the ash pan when activated. The riddling grate must be in semi-open position while the wood stove is lit.

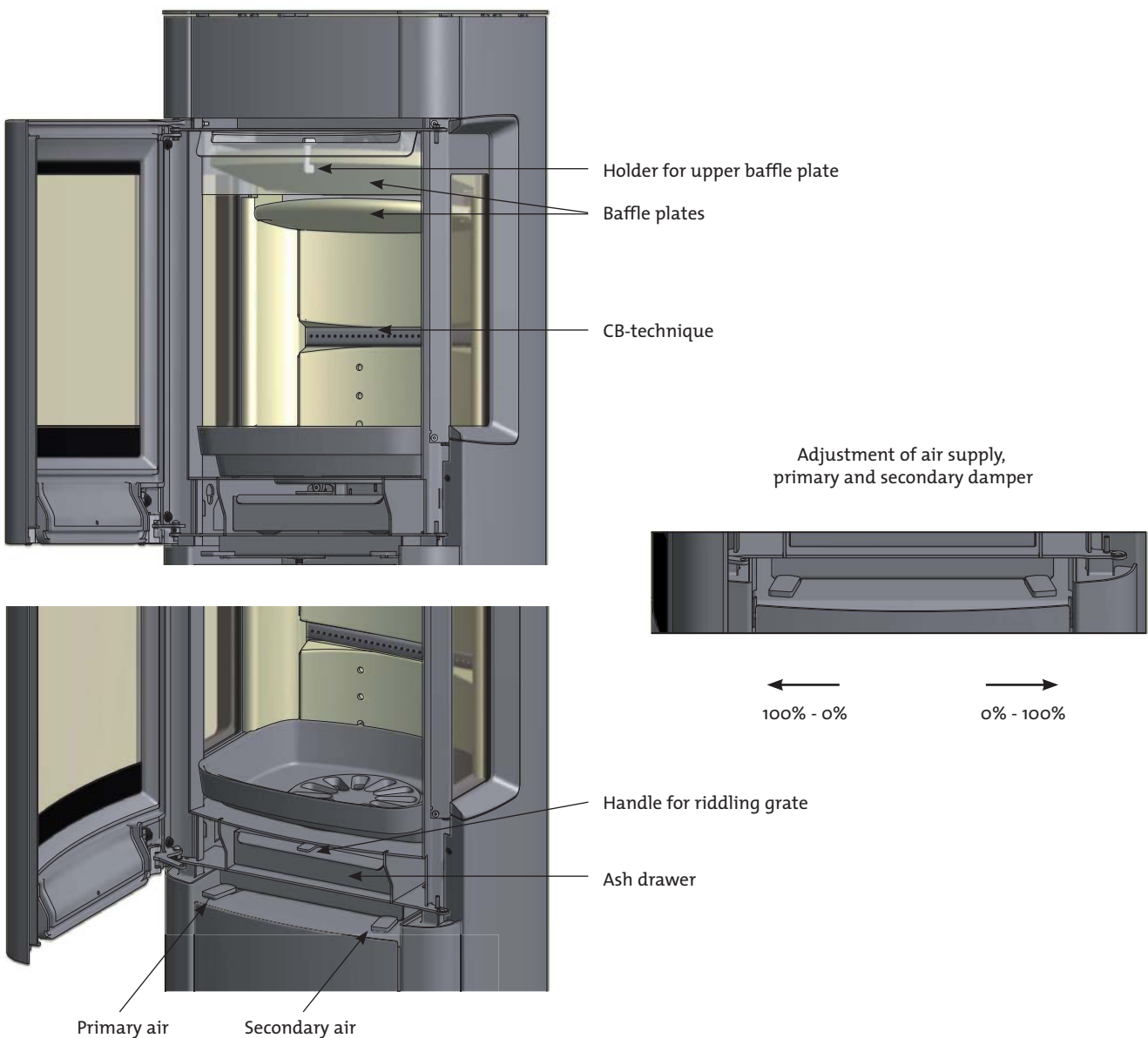

Environmentally-Friendly Heating

Avoid restricting your wood-burning stove to an extent where no flames are visible during the degasifying period, as this leads to particularly inefficient heating. The gases released by the wood do not burn due to the low temperature in the combustion chamber. Part of the gas condenses in the wood-burning stove and flue system as soot, and this could lead to your chimney catching fire. The smoke that exits the chimney is bad for the environment and has an unpleasant smell.

Lighting

We recommend the use of fire starters, or similar products, which are available from your Scan dealer. Using fire starters helps to light the wood quicker, and keeps the burning process clean. Never use liquid lighting fuels!

"Top down" optænding

4 pieces of wood approx. 20 - 23 cm long with a weight of approx. 0,5 - 0,6 kg per piece (image 1)

12 - 20 thin sticks of about 20 cm with a total weight of approx. 0,8 - 1,0 kg (image 2 - 5).

4 fire starters (image 6).

Place logs, sticks and fire starters in the combustion chamber as shown on images 1 - 5.

Set the primary and secondary airflow controls to maximum for about 20 - 30 minutes. When the larger pieces of wood have caught fire properly, you can set the primary and secondary airflow to the desired level.

"Top down" lighting gives a more environmentally friendly start to your fire and helps to keep the glass area as clean as possible.



Fire starters



Continuous firing

It is important to reach as high a temperature as possible in the combustion chamber. This makes the most efficient use of the wood stove and fuel, and ensures a clean burning process. At the same time, this avoids soot build-up on the combustion chamber walls and glass. While the stove is lit, you should not see any smoke, but just air movement that indicates the burning process.

After completing the lighting phase, you should have a good layer of embers in the wood stove; you can then start stoking up the stove. Lay 2-3 pieces of wood, of about 0.4 - 0.6 kg weight with a length of about 25 cm onto the fire.

Note! The wood must catch fire quickly; this is why we recommend setting the primary airflow to full power. Running the stove at too low a temperature and with too little primary air can lead to deflagration of the gases, and thus cause damage to the stove.

When stoking up with wood, always open the glass door carefully to avoid smoke escaping. Never stoke up with wood while the fire is still burning nicely.

Using your stove in the spring or autumn

In the transition period (spring/autumn), where there is less need for heating, we recommend to make a single „top down“ lighting, perhaps with one stoke up to ensure that the combustion chamber lining burns clean again.

Why you need a chimney

The chimney is the wood-burning stove's motor; it's performance decides how well your stove will work. The draft in the chimney creates a vacuum in the wood-burning stove. The vacuum draws the smoke out of the stove, and takes in air through the combustion air baffle to fuel the burning process. Combustion air is also used for the airwash system that keeps the window clear of soot.

The draft in the chimney is caused by the difference in temperatures inside and outside the chimney. The higher the temperature difference is, the better the draft in the chimney will be. It is thus important for the chimney to reach operating temperature before you adjust the damper to restrict combustion in the stove (a brickwork chimney will take longer to reach operating temperature than a steel chimney). It is very important to reach operating temperature as quickly as possible on days on which the draft in the chimney is poor due to unfavorable wind and weather conditions. Make sure the fuel ignites as quickly as possible (with visible flames). Chop the wood into particularly small pieces; use an extra fire lighter etc.

After longer periods of disuse, check the chimney flue for blockage.

You can connect several units to the same chimney. But make sure check with your chimney sweep to observe local regulations.

No matter how good your chimney is, it will not perform well if you do not use it correctly. On the other hand a poor chimney, may give you acceptable results if you use it correctly.

Using your stove in various weather conditions

Wind blowing on the chimney can have a great effect on how your stove reacts in various wind conditions; you may need to adjust the airflow to achieve good burning results. Fitting a damper in the flue pipe may also help as it will give you the ability to regulate the draught in changing wind conditions.

Fog can also have a great influence on how well a chimney draws; you may again need to adjust the airflow settings to achieve good burning results.

General Notes

Please note! Parts of the wood-burning stove, especially the outer surfaces, become hot during use. Please exercise due care.

Never empty ashes into a flammable container. Ashes can contain glowing embers long after you finish using your wood stove.

While the stove is not in use you can close the valves to avoid draught through the stove.

After longer breaks you should check the smoke outlet paths for blockages before lighting.

Chimney fires

In case of a chimney fire, keep the stove door, the ash container, and the valves on the stove closed. In case of emergency, call the fire service.

It is recommended that you get a chimney sweep to check the chimney before using the stove again.



Handling fuels

Selecting Wood/Fuel

You can use any type of wood as firewood, however, harder types, such as beech, ash, are generally better for heating as they burn more evenly and create less ash. Other wood types like maple, birch and spruce are excellent alternatives.

Handling

Firewood is best if you fell the tree, and saw and split the wood, before May 1st. Remember to cut the logs to match the size of your wood-burning stove's combustion chamber. We recommend a diameter of 6-10 cm. The length should be about 6 cm shorter than that of the combustion chamber to leave enough space for air to circulate. Firewood with a greater diameter needs splitting. Split wood dries faster.

Storing

You need to store the sawn and split firewood in a dry place for 1-2 years before burning. Wood dries faster if you stack it in an airy place. Before use, store the firewood for a few days at room temperature. Note that wood absorbs moisture during the autumn and winter seasons.

Moisture

To avoid environmental issues, and for optimum burning, wood has to be perfectly dry to be suitable for use as firewood. The maximum residual moisture in the wood should not exceed 20%. A moisture content of 15-18% yields best results. As an easy way of checking if wood is dry, just knock two pieces of wood together. If the wood is moist, the sound will be dull.

If you use damp wood, most of the heat it produces will be used to evaporate the water. The temperature in the wood stove does not rise, and the room is not sufficiently heated. Of course, this is not economical, and it will cause soot build up on the glass pane, in the stove, and in the chimney. Burning moist wood also causes pollution.

Understanding units for measuring wood

Various units of measurement are used for wood. Before you buy wood, it makes sense to familiarise yourself with the terms. There are various brochures, in public libraries for example, that cover this topic.

Use of the following as fuel is illegal

Painted, pressure impregnated, or glued wood, driftwood from the sea. Never burn chipboard, plastics, or chemically treated paper. These materials are dangerous to humans, to the environment, your wood stove, and your chimney. To keep a long story short – make sure you burn only quality firewood.

Firewood fuel value

The fuel value is different for different types of wood. In other words, you need to use more wood of certain types to achieve the same heating performance. This Instruction Manual assumes that you will be using beech, which has a very high fuel value, and is also a wood that is easy to procure. If you use oak or beech wood fuel, note that these wood types have a greater fuel value than, say, birch. Make sure you use less fuel to avoid damage to the wood-burning stove.

Wood types	Kg Dry wood/m ³	Compared to beech
Hornbeam	640	110%
Beech/Oak	580	100%
Ash	570	98%
Maple	540	93%
Birch	510	88%
Pine	480	83%
Fir	390	67%
Poplar	380	65%

Maintaining your wood-burning stove

Apart from regular chimney sweeping, your wood-burning stove does not require any regular maintenance. However, we recommend servicing at least once every two years

Use only original replacement parts for maintenance and repairs of your stove.

Note! Make sure the wood-burning stove is cold before starting maintenance or repair work.

Coated surfaces

Clean your wood-burning stove by dusting with a dry, lint-free cloth. If the topcoat is damaged, you can purchase a repair spray from your authorised Scan dealer. As slight differences in colour are possible, spray a larger area to achieve a natural transition for best results. For best results, apply repair spray when the wood-burning stove is hand-hot.

Cleaning the glass

Our wood-burning stoves are designed to prevent serious soot build up on the glass. The best way to achieve this is to make sure you have a sufficient combustion air supply. It is also important to use dry wood, and have a correctly dimensioned chimney.

Even if you follow all of our instructions, a slight film of soot can build up on the glass. You can easily remove this build up by cleaning with a dry cloth and glass cleaner. Your authorised Scan dealer stocks a special glass cleaner for this purpose.

Combustion chamber lining

Slight cracks can appear in the combustion chamber lining due to moisture, or to the heating/cooling process. These cracks have no influence on the heating performance or lifetime of your stove. However, if the lining starts to crumble, you must replace it. The combustion chamber lining is not covered by the warranty.

Gaskets

All wood-burning stoves have gaskets made of ceramic material fitted to the stove, the doors, and/or the glass. These gaskets are subject to wear and tear, and must be replaced when necessary.

Chimney sweeping and cleaning your wood-burning stove

Follow national and local chimney sweeping regulations. We recommend having the wood-burning stove cleaned regularly by the chimney sweep.

Before starting to clean your wood-burning stove, and sweep the flue pipe, we recommend first removing the baffle plates.

Checking the stove

Scan A/S recommends that you check your stove thoroughly after sweeping/cleaning. Check all visible surfaces for cracks. Check that all joints are tight and that the seals sit correctly. Worn or deformed seals should be replaced.

Servicing

- We recommend that the stove should have a comprehensive servicing at least once every two years. Servicing should include the following:
- Adjust handles and door
- Lubricate hinges using copper grease
- Check gaskets. Replace any that are broken or weak.
- Check combustion chamber door and riddling grate
- Check combustion chamber lining and baffle plates.

The stove must be serviced by a qualified fitter. Use only original spare parts.

Service

Baffle plates and combustion chamber lining

Be very careful when removing the baffle plates from the stove.

Lift up the lower baffle plate, remove the pins and take out the baffle plate.

Lift the upper baffle plate to the back of the combustion chamber. Remove pins. Pull the plate free from the baffle plate holder and remove it.

Lift the combustion chamber lining's sides, remove them from the rear cover and take them out.

Note that the combustion chamber lining's sides support the rear cover so this could fall when the sides are removed.

Remove the rear cover.

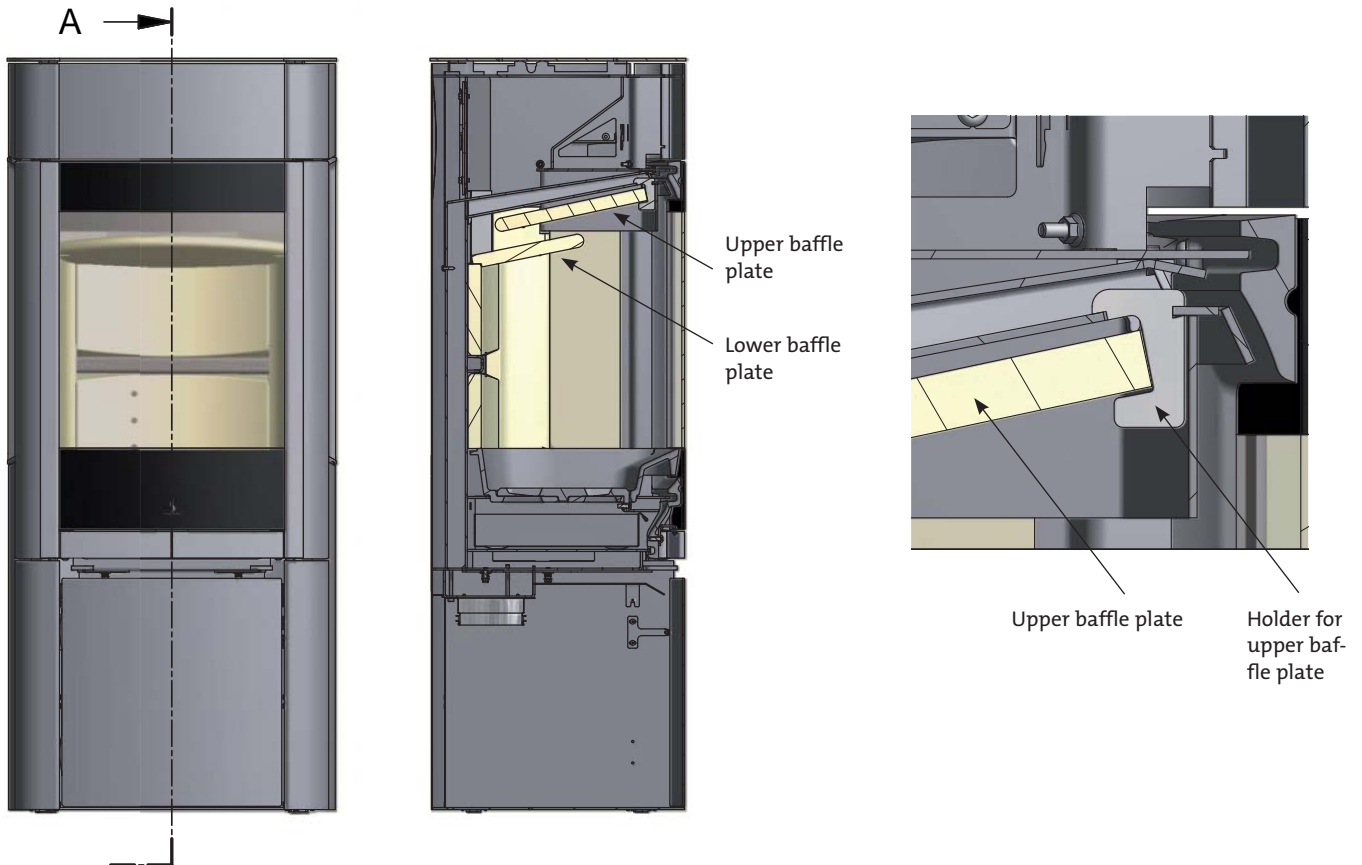

Scan 64-1, Scan 64-3 and Scan 64-5 (without side windows)

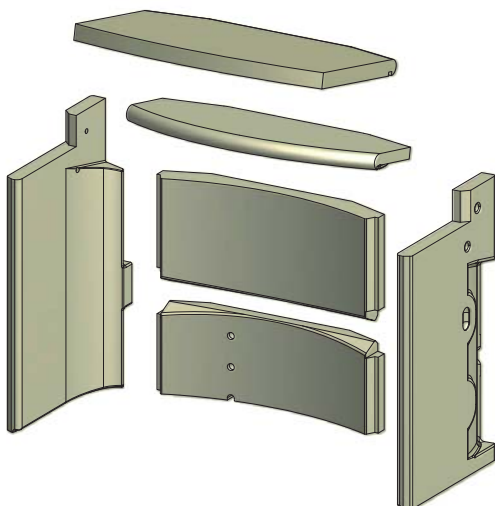

Scan 64-2, Scan 64-4 and Scan 64-6 (with side windows)

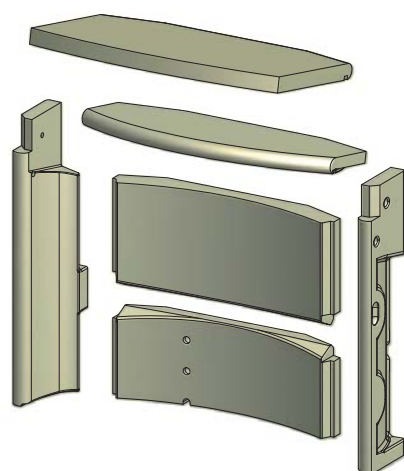

Smoke escaping

- Damp wood
- Chimney not drawing properly
- Chimney is not properly dimensioned for the stove
- Check if the smoke gas pipe/chimney are blocked
- Is the chimney the right height for its surroundings?
- At rear outlet, check that the flue pipe does not obstruct the chimney draught
- Vacuum in room
- The door is opened before the embers have burned down sufficiently

Wood burning too quickly

- The air valves are set incorrectly
- The baffle plates is incorrectly mounted or missing
- Inferior firewood (waste wood, pallets etc.)
- Chimney too large

Soot build-up on glass

- Incorrect secondary airflow setting
- Excessive primary air
- Damp wood
- Wood pieces too large on lighting
- Inferior firewood (waste wood, pallets etc.)
- Chimney not drawing sufficiently
- Vacuum in room

Excessive soot build-up in chimney

- Poor burning (more air required)
- Damp wood

The surface of the stove is turning grey

- Overheating (see instructions for heating)

Poor heating performance of stove

- Damp wood
- Not enough wood
- Inferior wood quality with low fuel value
- Baffle plates are not fitted correctly

Odour coming from stove

- The lacquer on the stove hardens when you use the stove for the first time; this can cause an odour. Open a window or a door for ventilation, and make sure the stove is heated up sufficiently to avoid odours later.
- When heating up and cooling down, the stove may make some clicking noises. These are due to the huge temperature differences to which the material is exposed and do not indicate any product defects.

Warranty

All wood-fired Scan products are made of high-quality materials and subject to strict quality controls before leaving the factory. We give a warranty of 5 years on manufacturing errors or defects.

You must quote your stove's product registration number when you contact us or your authorised Scan dealer with a warranty claim.

The warranty covers all parts which in the opinion of Scan A/S require repair or replacement due to manufacturing or construction error

The warranty applies to the original purchaser of the product only, and is not transferable (except on prior sale).

The warranty covers only damage caused by manufacturing or construction errors.

The following parts are not covered by the warranty

- Wear and tear parts, such as the combustion chamber liners, baffle plates, riddling grate, glass, tiles, and seals (except for defects which were present on delivery).
- Defects caused by external chemical and physical influences during transportation, storage and assembly, or at a later time.
- Soot build-up caused by poor chimney draught, damp wood, or improper use.
- Costs of additional heating in connection with a repair.
- Transport costs.
- Costs for setting up, removing the wood stove.

This warranty is void

- In case of incorrect installation (the installer is responsible for observing and complying with legal requirements and local bylaws, along with this Assembly- and Instructions manual for the wood-burning stove and accessories).
- In case of improper use, and/or use of prohibited fuels, non-original spares (see this Assembly- and instructions manual).
- If the product registration number of the stove has been removed or damaged.
- In case of repairs that do not comply with our instructions or instructions by an authorised Scan dealer.
- In case of any manipulation of the original state of this Scan product or its accessories.
- This warranty is only valid in the country to which this Scan product was originally supplied.

Always use original replacement parts, or parts recommended by the manufacturer.

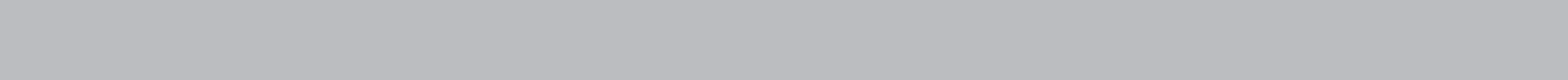

Version:
GB 90064500
08.11.2011

Scan A/S - DK-5492 Vissenbjerg

