

# Scan

## Basic 4-5



### Content

#### The Product

Product registration number

#### Installation

Installation

Approval

Positioning the stove

Position in relation to non-flammable walls

Distance to flammable walls

Technical data and dimensions

#### Assembly

Unpacking

Service package

Load bearing underlay

Floor plate

Adjusting screw

Smoke gas connecting piece rear outlet

Smoke gas connecting piece top outlet

Adapter between top outlet and steel flue

Assembly with 90° knee pipe

Requirements for flue

Fresh air supply

Assembling the fresh air connecting piece and valve

#### Instruction Manual

CB Technology

Primary air

Secondary air

Smoke deflector platens

#### Instructions for lighting

Lighting

Handling fuels

#### Maintenance

#### Troubleshooting

## Congratulations on the purchase of your new Scan stove

You have purchased a product by one of Europe's leading manufacturers of stoves, and we are sure that you will have years of pleasure with your purchase. To make the best possible use of your stove, it is important that you follow the advice and instructions in this manual.

**Please read the assembly instructions and instructions for use before you start to assemble your stove.**

123456

Make a note of your stove's product registration number here so that you have it available if you need to contact us.

Approved according to  
EN 13240



Version GB 08.08.07 - 1

## Installation

When you install any kind of fireplace or stove, you must inform the local authorities. The house owner is responsible for ensuring that all necessary safety measures are observed, and also responsible for calling in a chimney sweep to inspect and authorise the installation.

## Approval

If you intend to connect your stove to an existing flue, it would be advisable to contact an authorised Scan dealer, or a local chimney sweep for advice. These experts will also let you know if your flue needs renovating.

On connecting to a multiple element flue: Follow the vendor's instructions as applicable to the flue type (e.g. Leca, Plewa, Icopal, Isokern, Zanda etc.)

No matter whether an authorised Scan dealer installs your stove, or you do the job yourself, remember that the chimney sweep has to approve the installation before you start to use it.

## Positioning the stove

The woodstove must be set up so that the stove itself, the smoke gas pipe, and the flue can all be cleaned.

## Position in relation to non-flammable walls

When positioning near a non-flammable wall, keep a minimum distance of 50mm between the rear of the product and the wall.

## Distance to flammable walls

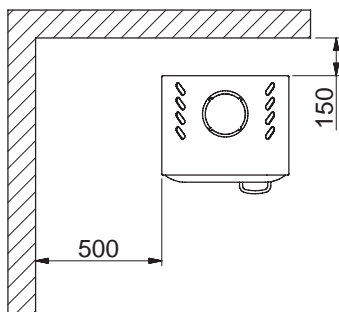
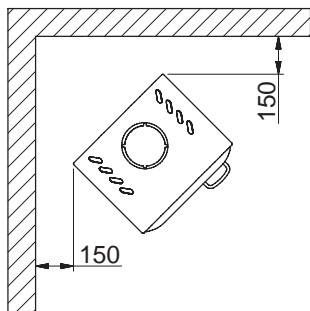

Distance to furniture: 1100 mm

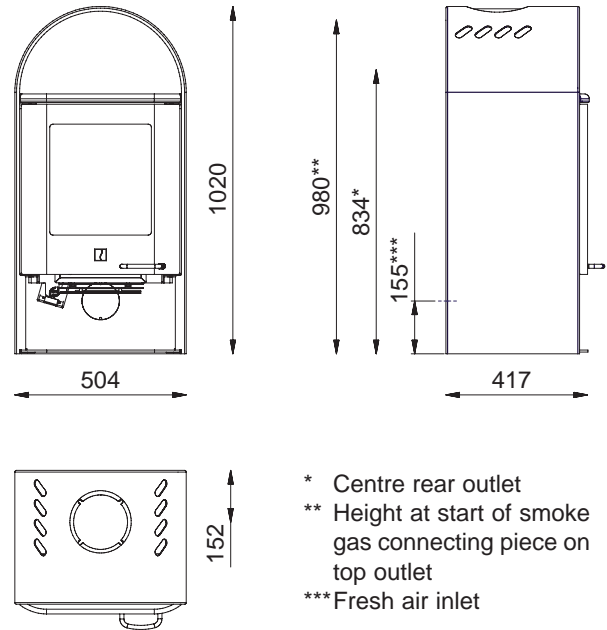

- \* Centre rear outlet
- \*\* Height at start of smoke gas connecting piece on top outlet
- \*\*\* Fresh air inlet

## Technical data and dimensions

CO Emission at 13% O <sub>2</sub> :	0,11%
Efficiency:	78%
Nominal heat output:	6 kW
Flue temperature:	251°C
Smoke output:	7,1 g/sec.
Recommended underpressure in smoke gas connecting piece:	16 Pa
Recommended fuel:	Wood
Fuel capacity:	1,7 kg
Min./max. heating performance (vendor specification):	3-7 kW
Weight	122 kg
Smoke gas connecting piece internal diameter:	135 mm
Smoke gas connecting piece external diameter:	148 mm
Approved for:	Intermittent fuelling

Intermittent fuelling means normal use of a woodstove. In other words, you should let the fire die down until only the embers are left, before refuelling.

The Scan Basic 4-5 was built in compliance with the homologised product type specified in the Assembly and Instruction Manual provided with the product.

## Unpacking

To protect your stove, we recommend that you do not remove the plastic packaging from the stove until you have completed assembly.

## Service package

The service package comprises the following:

- Smoke gas connecting piece
- Ball valve
- Plastic plugs for transport safety bores at the bottom of the stove
- Various tools
- Hook for shaker grate
- Glove
- Fire starters for first lighting
- Seal for connecting piece

## Load bearing underlay

All of the products in our portfolio are classified as light-duty fireplaces; in most cases, there is no need to reinforce the floor, so you can typically use the normal floor.

## Floor plate

The floor plate is designed to protect the floor and flammable material against sparks.

As a general rule, the floor plate should cover the floor 300 mm to the front, and 150 mm to the side of the wood stove door. The floor plate can be made of steel or glass, and the stove can be installed on brick, natural stone or similar materials.

This Scan wood oven has an integrated floor plate and is approved for installation directly on flammable material.

## Adjusting screw

Your Scan wood stove has two adjusting screws at the base which you can use to level the stove.

## Setting up the stove for use with a rear outlet

### Smoke gas connecting piece rear outlet

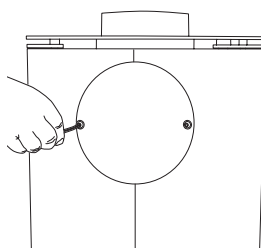

1. Use the tools provided to remove the cover plate at the rear of the wood stove.

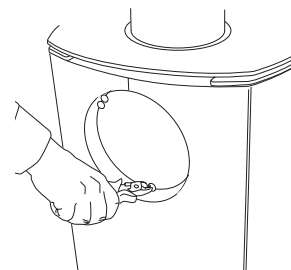

2. Use a pincers to cut off the anchoring points on the internal plate.

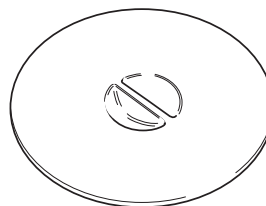

3. Loosen the internal cover (boiler plate) from the inside and remove. You will need this plate later as a seal and cover for the top plate.

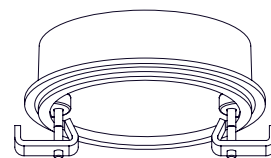

4. Attach the loose connecting piece from the outside and fix in place with the fittings provided from the the service package.

5. Insert the boiler plate into the smoke outlet at the top. Insert the cover plate into the hole in the top plate.

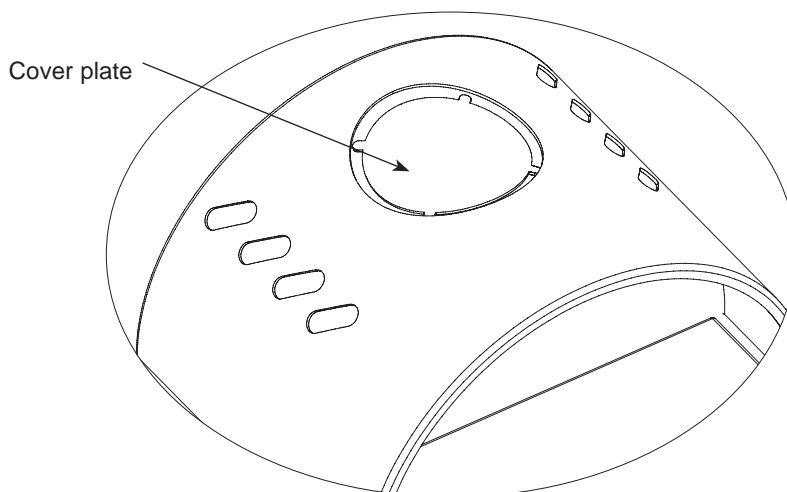

### Smoke gas connecting piece top outlet

This wood stove has been prepared for a rear outlet by the manufacturer. Lift the cover plate off the top plate and fit the smoke gas connecting piece, the seal, and the fittings from the service package (see page 3). At the same time, screw down the ball stopper crosswise to prevent damage to the smoke deflector plate when sweeping the chimney.

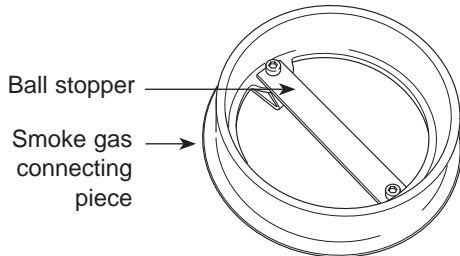

### Connection between top flue outlet and steel chimney

Your Scan dealer, or local chimney sweep, can advise you on choosing a make and type of steel chimney. This ensures that the chimney will match your wood stove. As a general rule, the length of the flue should not be less than 3.5 m measured from the top of the wood stove. Choosing the wrong length or diameter of steel chimney could impair functionality.

Always observe the chimney vendor's instructions precisely.

### Assembly with 90° knee pipe

You can also connect your wood stove using a 90° knee pipe at the top outlet.

The cleaning flap on the knee pipe should be located in the vertical section to allow cleaning of the horizontal section through it.

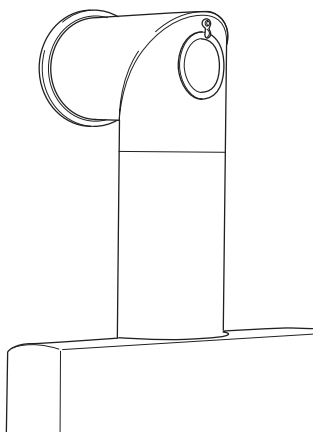

### Requirements for flue

The flue must be labelled T400 and G for soot testing.

### Fresh air supply

In a well-insulated house, the air used up by the burning process has to be replaced. This particularly applies to houses with mechanical ventilation. There are different ways of making sure that an air exchange takes place. The most important thing is to ensure that there is a supply of air to the room where the wood stove is located. The external wall valve must be located as close to the wood stove as possible, and you must be able to close it when you are not using the wood stove.

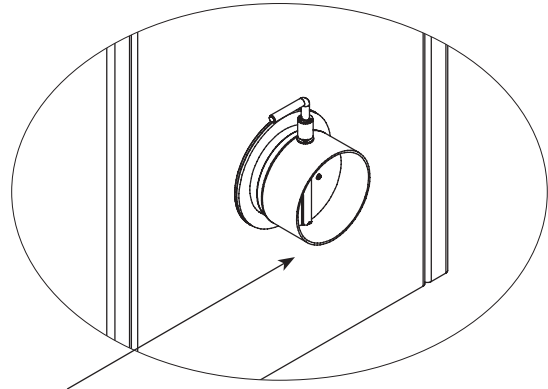

Fresh air connecting piece with valve

### Assembling the fresh air connecting piece and valve

If you ordered a fresh air connecting piece, please mount it as shown below.

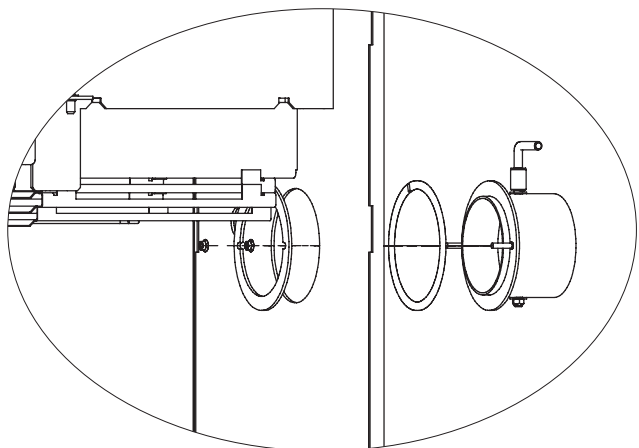

### CB Technology (Clean Burning)

Your wood stove is fitted with CB technology. To ensure optimum burning of the gases released by the burning process, air is guided by a specially developed system. Pre-heated air is fed into the combustion chamber through the small holes below the smoke deflector plate. The airflow is driven by the combustion speed and cannot be regulated.

### Primary air

The primary air regulation mechanism is used for lighting the fire, or to boost the burning process when you put wood on. The primary air vent can be 25-50% open if you use hard wood fuel such as oak and beech. You can close the primary air vent if you use soft wood such as birch or pine for fuel.

### Secondary air

Secondary air is pre-heated and fed directly to the fire. At the same time, the secondary airflow cleans the glass pane to prevent soot build-up. If you over-restrict the secondary airflow, soot can build up on the glass pane. The secondary airflow determines the heat output from your wood stove.

### Smoke deflector platens

The smoke deflector platens are located in the upper part of the combustion chamber. The platens hold back smoke, making sure it stays inside the combustion chamber for a longer time before escaping through the chimney.

This reduces the smoke gas temperature as the gases have more time to dissipate heat to the wood stove. The smoke deflector platens must be removed for sweeping; see "Wood stove maintenance".

Note that the smoke deflector platens are made of porous, ceramic material, and can break. Exercise care when working. The smoke deflector platens are subject to wear and tear, and are not covered by the warranty.

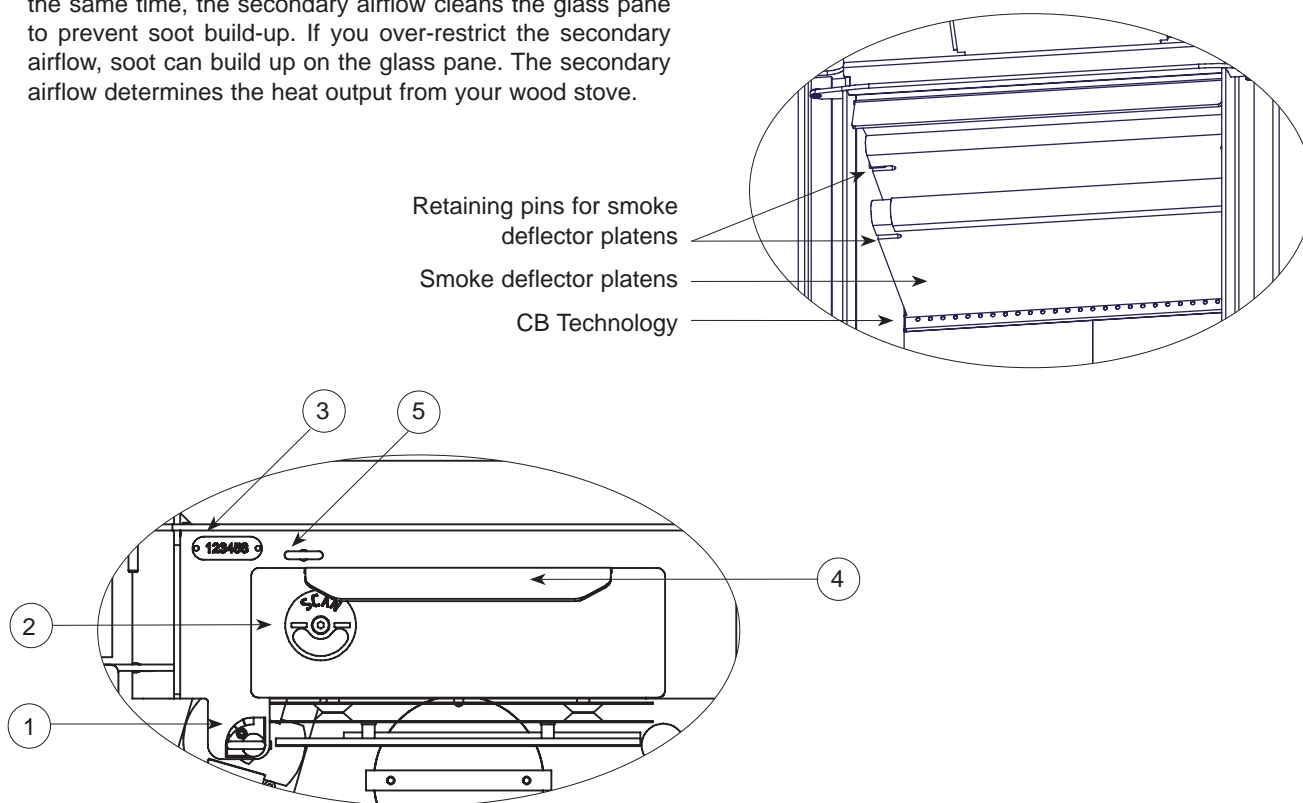

- ① **Secondary airflow control.** Turn the switch to control the secondary airflow.
- ② **Primary airflow control.** Turn the switch to control the primary airflow.
- ③ **Product registration number.**
- ④ **Ash drawer.** Open the glass door to access the ash drawer which is located below the combustion chamber. **Important note!! Never empty ashes into a flammable container. Ashes can contain glowing embers long after you finish using your wood stove.**

- ⑤ **Handle for shaker grate.** Your wood stove is fitted with a shaker grate which empties the ash from the combustion chamber into the ash drawer when activated. The shaker grate must be in semi-open position while the wood stove is lit.

### Setting for normal load

Secondary air %	Primary air %	Fuel quantity/kg	Chimney flue, min. Pa	Fuel consumption kg/h	Efficiency in %
75	50	1,7	12	1,7	78

## Lighting

We recommend the use of fire starters, or similar products, which are available from your Scan dealer. Using fire starters helps to light the wood quicker, and keeps the burning process clean.

**Never use liquid lighting fuels!**

### “Top down” lighting

2 pieces of wood approx. 30 cm long with a weight of approx. 0.8 – 1.2 kg per piece.

1 piece of wood approx. 25 cm long with a weight of about 0.5 kg.

6 - 12 thin sticks of about 20 cm with a total weight of approx. 400 g.

3 fire starters.

Place the two large pieces of wood crossways at the centre of the combustion chamber, at a distance of 1 – 2 cm apart. Loosely place the sticks on top. Place the fire starters between the sticks and light. Place the smaller piece of wood onto the sticks at a slight angle to the two larger pieces. Set the primary and secondary airflow controls to maximum for about 20 - 30 minutes. When the two larger pieces of wood have caught fire properly, you can set the primary and secondary airflow to the desired level.

“Top down” lighting is environmentally friendly

## Continuous firing

It is important to reach as high a temperature as possible in the combustion chamber. This makes the most efficient use of the wood stove and fuel and ensures a clean burning process. At the same time, this prevents soot build-up on the combustion chamber walls and glass. While the stove is lit you should not see any smoke, just air movement that indicates the burning process.

After completing the lighting phase, you should have a good layer of embers in the wood stove; you can then start stoking up the stove. Lay 2 pieces of wood, of about 0.8 kg weight with a length of about 30 cm onto the fire.

**Note! It is important for the wood to catch fire quickly. Use primary air control to make sure this happens.**

**Not putting on enough fuel can cause gases to ignite, and this can damage your wood stove.**

When stoking up with wood, always open the glass door carefully to prevent smoke escaping. Stoke up with wood while the fire is still burning nicely.

## Using your stove in the spring or autumn

Occasional lighting of the stove using the “top down” lighting method (see above) is recommended in changeable weather such as in spring/autumn when your heating requirements are not as great.

## Using your stove in various weather conditions

Wind blowing on the chimney can have a great effect on how your stove reacts in various wind conditions; you may need to adjust the airflow to achieve good burning results. Fitting a flap in the smoke pipe may also help as it will give you the ability to regulate the draught in changing wind conditions.

Fog can also have a great influence on how well a chimney draws; you may again need to adjust the airflow settings to achieve good burning results.

## General notes.

Your wood stove is not designed for continual heating for periods of over 24 hours. After longer breaks you should check the smoke outlet paths for blockages before lighting.

**Please note! Parts of the wood stove, especially the outer surfaces, become hot during use. Please exercise due care.**

## Chimney fires

In case of a chimney fire, keep the stove door, the ash drawer, and all the valves on the stove closed. In case of emergency, call the fire service.

## Handling fuels

### Handling

Firewood is best if you fell the tree and saw and split the wood before May 1. Remember to cut the logs to fit the size of your wood stove's combustion chamber. We recommend a diameter of 6-10 cm. The length should be about 6 cm shorter than that of the combustion chamber to leave enough space for air to circulate. Firewood with a greater diameter should be split.

Split wood dries better.

### Storage

The sawn and split firewood should be stored in a dry place for 1-2 years before burning. Wood dries faster if you stack it in a well-ventilated area. Before use, store the firewood for a few days at room temperature. Note that wood absorbs moisture during the autumn and winter seasons.

### Moisture

To avoid environmental issues, and for optimum burning, wood has to be perfectly dry to be suitable for use as firewood. The max. residual moisture in the wood should not exceed 21%. A moisture content of 15-18% yields best results. An easy way of checking if wood is dry is to knock two pieces of wood together. If the wood is moist, the sound will be dull.

If you use damp wood, most of the heat it produces will be used to evaporate the water. The temperature in the wood stove does not rise and the room is not sufficiently heated. Of course, this is not economical and it will cause soot build up on the glass pane in the stove and in the chimney. Burning moist wood also causes pollution.

## Understanding units for measuring wood

Various units of measurement are used for wood. Before you buy wood, it makes sense to familiarise yourself with the terms. There are various brochures available in public libraries for example, that cover this topic.

## Use of the following materials as fuel is illegal

Painted, pressure impregnated, or glued wood, driftwood from the sea. Never burn chipboard, plastics, or chemically treated paper. These materials are dangerous to humans, to the environment, your wood stove and your chimney. In short – make sure you only burn quality firewood.

**If the glass and the combustion chamber walls are clean, this normally indicates a clean burning process.**



### Firewood fuel value

The fuel value varies for different types of wood. In other words, you need to use more wood of certain types to achieve the same heating performance. This Instruction Manual assumes that you will be using beech which has a very high fuel value and is also a wood that is easy to procure. If you use oak or beech, not that these types of wood have a greater fuel value than e.g. birch. In this case, reduce the fuel quantity to avoid damage to your wood stove.

Wood types	kg Dry wood/m <sup>3</sup>	Compared to beech
Hornbeam	640	110%
Beech/oak	580	100%
Ash	570	98%
Maple	540	93%
Birch	510	88%
Pine	480	83%
Spruce	390	67%
Poplar	380	65%

### Maintaining your wood stove

Apart from regular chimney sweeping, your wood stove does not require any regular maintenance.

#### Coated surfaces

Clean your wood stove by dusting with a dry, lint-free cloth.

If the topcoat is damaged, you can purchase a repair spray from your authorised Scan dealer. As slight differences in colour may occur, spray a larger area to achieve a natural transition for best results. For best results, apply repair spray when the wood stove is hand-hot.

#### Combustion chamber lining

Slight cracks can appear in the combustion chamber lining due to moisture, or to the heating/cooling process. These cracks have no effect on the heating performance or lifetime of your stove. However, if the lining starts to crumble, it should be replaced. The combustion chamber lining is not covered by the warranty.

#### Cleaning the glass

Our wood stoves are designed to prevent serious soot build up on the glass. The best way to achieve this is to make sure you have a sufficient secondary air supply. It is also important to use dry wood, and have a correctly dimensioned chimney.

Even if you follow all of our instructions, a slight film of soot can build up on the glass. You can easily remove this build up by cleaning with a dry cloth and glass cleaner. Your authorised Scan dealer stocks a special glass cleaner for this purpose.

#### Seals

All wood stoves have seals made of ceramic material fitted to the stove, the doors, and/or the glass. These seals are subject to wear and tear and must be replaced when necessary.

#### Removing the smoke deflector platen

Lift the lower smoke deflector platen, remove the pins at the sides, and then remove the platen. Remove the upper smoke deflector platen in the same way.

### Cleaning your wood stove

Before starting to clean your wood stove, and sweeping the smoke gas pipe, we recommend first removing the smoke deflector platens.

**Use only original replacement parts for maintenance and repairs of your wood stove.**

**Note! Make sure the stove is cold before starting maintenance or repair work.**

### List of Spare Parts

Purchase goods no..	Description	Quantity
	<b>Combustion chamber:</b>	
50100131 000	Smoke gas connecting piece	1
54940000 000	Smoke deflector platen, top	1
50500134	Pins for smoke deflector platen	4
54940000 0001	Smoke deflector platen, bottom	1
50500134	Pins for smoke deflector platen	2
50100146 025	Reinforcement for smoke deflector platen	1
53940999 00020	Combustion chamber liner, right	1
53940999 00030	Combustion chamber liner, left	1
53940999 00010	Combustion chamber liner, back	2
53940999 00050	Combustion chamber flooring, front	1
53940999 00052	Combustion chamber flooring, sides	2
53940000 000	Combustion chamber liner, complete	1
50100111	Shaker grate, complete	1
50100110	Top part of shaker grate	1
50100112 940	Shaker grate bar	1
50100140 940	Wood retainer	1
50100142 940	Front spoiler	1
	<b>Door:</b>	
57940012	Glass	1
55300025	Glass seal	1 m
50500140 9400	Hinge door, top	1
50500140 9401	Hinge door, bottom	1
50500137 940	Locking hook, incl. grub screw and washer	1
50500139 940	Closing axis	1
58910002 4	Handle	1
55300021	Seal for door	1 m
	<b>Ash drawer:</b>	
50100150 940	Ash drawer, complete	1
55100005	Seal for ash drawer	0,6 m
50500138 03	Primary slider on ash drawer	1
50500115 940	Secondary controls complete	1

### Smoke escaping

- Damp wood
- Chimney not drawing properly
- Chimney is not properly dimensioned for the stove
- Check if the smoke gas pipe/chimney are blocked
- Is the chimney the right height for its surroundings
- In case of rear outlet, check that the smoke gas pipe does not reach into the chimney core pipe
- Underpressure in room

### Wood burning too quickly

- The air valves are set incorrectly
- The smoke deflector platen is incorrectly mounted or missing
- Inferior firewood (waste wood, pallets etc.)
- Chimney too large

### Soot build-up on glass

- Incorrect secondary airflow setting
- Excessive primary air
- Damp wood
- Wood pieces too large on lighting
- Inferior firewood (waste wood, pallets etc.)
- Chimney not drawing sufficiently
- Underpressure in room

### Excessive soot build-up in chimney

- Poor burning (more air required)
- Damp wood

### Shaker grate is blocked

- Check if something is jammed, nails etc.
- The rod on the shaker grate is sitting incorrectly

### The surface of the wood stove is turning grey

- Overheating (see burning instructions)

### Poor heating performance of stove

- Damp wood
- Not enough wood
- Inferior wood quality with low fuel value
- Smoke deflector platens are not fitted correctly

### Odour coming from stove

- The lacquer on the stove hardens when you use the stove for the first time; this can cause an odour. Open a window or a door for ventilation and make sure the stove is heated up sufficiently to prevent odours later.



### Warranty

All wood-fired Scan products are made of high-quality materials and subject to strict quality controls before leaving the factory. We provide a five-year warranty on manufacturing errors or defects.

You must quote your stove's product registration number when you contact us or your authorised Scan dealer with a warranty claim.

The warranty covers all parts which, in the opinion of Krog Iversen & Co. A/S, require repair or replacement due to manufacturing or construction error

The warranty applies to the original purchaser of the product only, and is not transferable (except on prior sale).

The warranty covers damage caused by manufacturing or construction errors only.

### The following parts are not covered by the warranty

- Wear and tear parts such as the combustion chamber liners, smoke deflector platens, shaker grate, glass, tiles, and seals (except for defects which were present on delivery).
- Defects caused by external chemical and physical influences during transportation, storage and assembly, or at a later time.
- Soot build-up caused by poor chimney draught, damp wood, or improper use.
- Costs of additional heating in connection with a repair.
- Transport costs.
- Costs for setting up, removing the wood stove.

### This warranty is invalid

- In case of incorrect installation (the installer is responsible for observing and complying with legal requirements and local bylaws, along with the instructions in the Assembly Instructions and Instructions for Use supplied with the wood stove and accessories).
- In case of improper use, and/or use of prohibited fuels, non-original spares (see the Assembly Instructions, Instructions for Use, and Instructions for Lighting)
- If the product registration number of the stove has been removed or damaged.
- In case of repairs that do not comply with our instructions or instructions by an authorised Scan dealer.
- In case of any manipulation of the original state of this Scan product or its accessories.
- This warranty is only valid in the country to which this Scan product was originally supplied.

Always use original replacement parts, or parts recommended by the manufacturer.