

# Scan DSA 10



## Congratulations on your new Scan wood-burning stove

You have purchased a product by one of Europe's leading manufacturer's of wood-burning stoves, and we are sure that you will have years of pleasure with your purchase. To make the best possible use of your stove, it is important that you follow our advice and instructions.

**Please read this Assembly- and instructions manual before you start to assemble your stove.**

123456

Make a note of your stove's product registration number here so that you have it available if you need to contact us.

**Test in compliance with  
EN 13240**



Version GB 25.11.08 - 1

## Indholdsfortegnelse

|  |    |
|--|----|
| Installation .....                           | 3  |
| Installation                                 |    |
| Approval                                     |    |
| Technical data and dimensions                |    |
| Dimension sketch                             |    |
| Assembly .....                               | 4  |
| Unpacking                                    |    |
| Service package                              |    |
| Type plate                                   |    |
| Product registration number                  |    |
| Door   |    |
| Accessories                                  |    |
| Load bearing underlay                        |    |
| Floor plate                                  |    |
| Adjusting screws                             |    |
| Stainless-steel shelf                        |    |
| Positioning your wood-burning stove          |    |
| Position in relation to non-flammable walls  |    |
| Distance to flammable walls                  |    |
| Distance to furniture                        |    |
| Connection between stove and steel chimney   |    |
| Requirements for chimney                     |    |
| Preparing the stove for top/side/rear outlet |    |
| Connection with 90° elbow pipe               |    |
| Connection for rear/side outlet              |    |
| Flue pipe with damper                        |    |
| Fitting the damper                           |    |
| Fresh air intake                             |    |
| Fitting the fresh-air connection piece       |    |
| Instruction for use .....                    | 8  |
| CB Technology                                |    |
| Combustion air                               |    |
| Smoke deflector plates                       |    |
| Instructions for heating .....               | 9  |
| Lighting                                     |    |
| Handling fuels                               |    |
| Maintenance .....                            | 11 |
| Troubleshooting .....                        | 12 |

## Installation

The house owner is responsible for ensuring that all necessary national and local safety measures are observed during installation and fitting and also responsible for observing the fitting and operating instructions detailed in this manual.

When you install any kind of fireplace or stove, you must inform the local authorities. You are also responsible for calling in a chimney sweep to inspect and authorize the installation.

To ensure best-possible functionality and safety for your installation, we advise you to call a professional fitter. Our Scan Dealer will be able to recommend a qualified fitter in your area. For information on Scan Dealers, please go to [www.scan.dk](http://www.scan.dk).

## Approval

If you intend to connect your stove to an existing chimney, it makes sense to contact an authorised Scan dealer, or a local chimney sweep for advice. These experts will also let you know if your flue needs renovating.

On connecting to a multiple element chimney: follow the vendor's instructions as applicable to the chimney type (e.g. Leca, Plewa, Icopal, Isokern, Zanda etc.)

No matter whether an authorised Scan dealer installs your stove, or you do the job yourself, remember that the chimney sweep has to approve the installation before you start to use it.

## Technical data and dimensions

|  |       |                         |
|--|-------|-------------------------|
| CO Emission at 13% O <sub>2</sub> :    | 0,09% | 1135 mg/Nm <sup>3</sup> |
| Dust @ 13% O <sub>2</sub> :            |       | 29 mg/Nm <sup>3</sup>   |
| No <sub>x</sub> @ 13% O <sub>2</sub> : |       | 121 mg/Nm <sup>3</sup>  |
| Efficiency:                            |       | 81%                     |
| Rated heat load:                       |       | 8 kW                    |
| Chimney temperature:                   |       | 270°C                   |
| Flue outlet flow:                      |       | 8,5 g/sek               |
| Recommended vacuum in flue collar:     |       | 16 Pa                   |
| Combustion air requirement:            |       | 24 Nm <sup>3</sup> /h   |
| Recommended fuel:                      |       | Wood                    |
| Fuel consumption:                      |       | 2,5 Kg/h                |
| Amount of fuel:                        |       | 2 kg                    |
| Weight:                                |       | 178 kg                  |
| Flue collar internal diameter:         |       | 175 mm                  |
| Flue collar external diameter:         |       | 180 mm                  |
| Approval type:                         |       | Intermittent fuelling   |

Intermittent fuelling means normal use of a woodstove. In other words, you should let the fire die down until only the embers are left, before refuelling.

The Scan DSA 10 was build in compliance with the homologized product type specified in the Assembly- and Instructions Manual provided with the product.

Dimension sketch Scan DSA 10

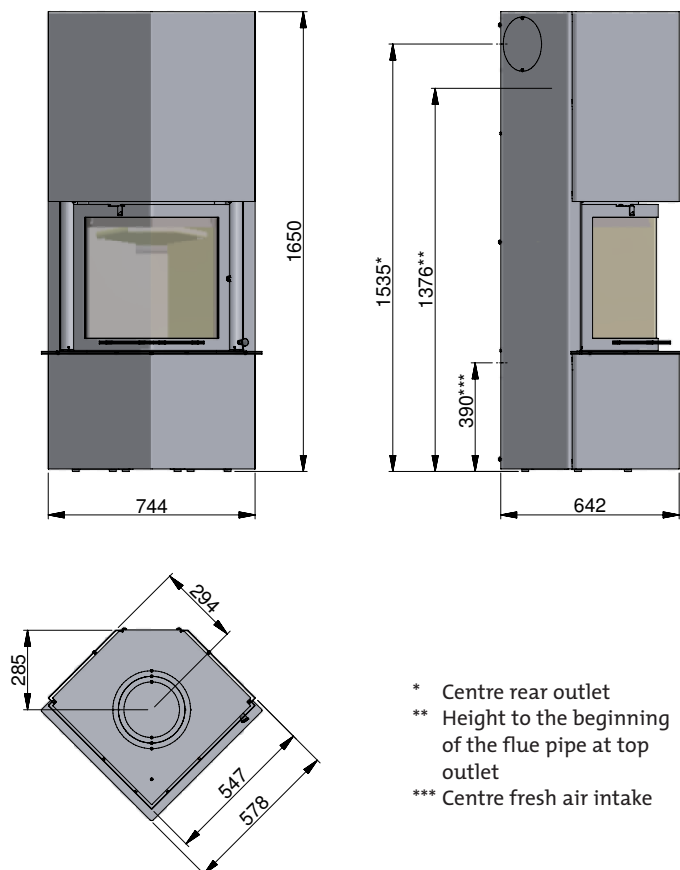

## Unpacking

To protect your stove, we recommend not removing the plastic packaging from the stove until you have completed the assembly.

## Service package

The service package contains the following:

- Fitting for flue collar (not required for this stove)
- Seal for flue collar (not required for this stove)
- Safety fitting (not required for this stove)
- Plastic plugs for transport safety hole at the bottom of the stove (not required for this stove)
- Various tools
- Glove
- Fire starters for first lighting

## Type plate

All Scan wood-burning stoves are fitted with a type plate, that specifies the approval standards and the distance to flammable materials.

**Scan DSA 10** CE  
 Freestanding room heater fired by solid fuel

**Standard:**      **EN 13240**      **EC no. 90081600**

Minimum distance to combustible materials:  
 Side: 550 mm - Back: 150 mm - Front: 1000 mm

CO emission at 13% O<sub>2</sub>:                      0,09%      1135 mg/Nm<sup>3</sup>  
 Dust CO emission at 13% O<sub>2</sub>:                      29 mg/Nm<sup>3</sup>  
 Flue gas temperature:                              270°C  
 Nominal heat output:                              8 kW  
 Efficiency:    81%  
 Fuel type:    Wood  
 Operation type:                                      Intermittent  
 The appliance can be operated in a shared flue.

| Country | Classification | Certificate/Standard | Approved by  |
|---------|----------------|----------------------|--------------|
| EUR     | Intermittent   | EN 13240             | RWE Power AG |
| Norway  | Klasse 2       | SINTEF 110-0262      | SINTEF - NBL |
| Schweiz | LRV 11         | VKF N 17943          | RWE Power AG |
| Germany | BStV 1         | FSPS-Wa 1646-EN      | RWE Power AG |

Follow assembly- and instructions for use.  
 Use only recommended fuels.

Montage- und Bedienungsanleitung beachten.  
 Verwenden Sie nur empfohlene Brennstoffe.

1000      Scan A/S DK 5492 Vissenbjerg      11-2008

## Product registration number

Remove the front shelf carefully; you can then read, and make a note of, the product registration number (see front).

Product registration number

Fastener

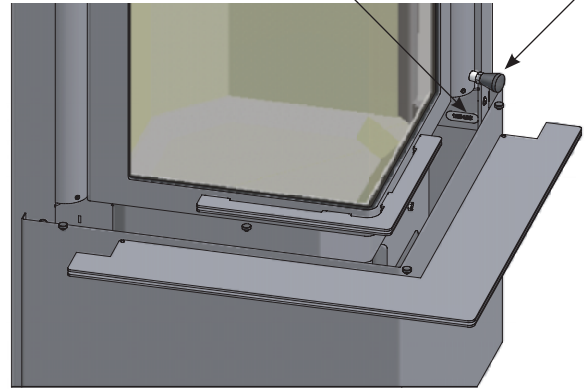

## Door

The stove door is locked on delivery. To open the door, pull out and turn the fastener. Do not use the fastener under normal circumstances to avoid scratches and unnecessary wear and tear on the guide axis.

If you want to hold the door at the top position, the fastener is used for doing so.

## Accessories

The following accessories are available for this model

- Deco angle
- Flue cover
- Front shelf in the following materials:  
 Stainless steel  
 Black glass  
 Frosted glass
- Connection piece for fresh air intake

### Load bearing underlay

All of the products in our portfolio are classified as light-duty fireplaces; in most cases, there is no need to reinforce the floor, so that you can typically use the normal floor.

However, you should make sure that the load bearing underlay can bear the weight of the wood-burning stove and that of the chimney.

### Floor plate

If you are setting up the stove on a flammable floor, observe national and local regulations on the size of the non-flammable underlay that covers the floor around the stove.

Your local Scan dealer can advise you on regulations concerning flammable materials in the vicinity of your stove.

The idea behind the floor plate is that it protects the floor and flammable material against sparks.

The floor plate can be made of steel or glass, and the stove can be set up on brick, natural stone or similar materials.

This Scan wood-burning stove has an integrated floor plate, and can thus be set up on any flammable material without a protective underlay.

### Adjusting screw

Your Scan wood-burning stove has 6 adjusting screws at the base which you can use to level the stove.

Afmonter hylde og nederste svøb hvorpå justering kan foretages (anvend evt. nøgle fra servicepakken).

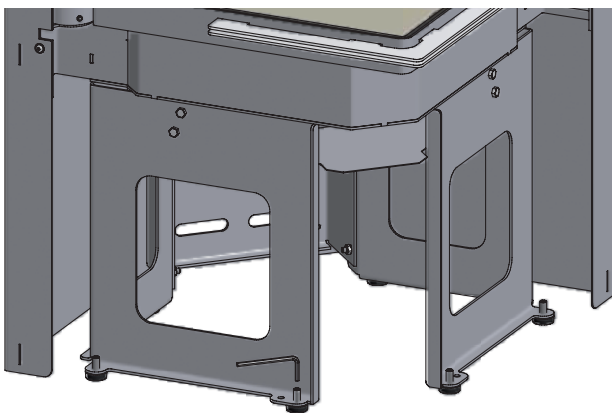

### The stainless-steel shelf at the front is mounted as follows:

Press the spacers into the holes on the lower plate and mount the plate on the oven. Then the upper plate is laid on the spacers.

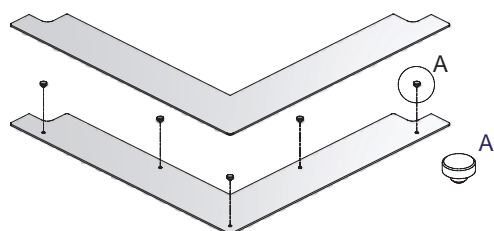

### Positioning your wood-burning stove

The wood-burning stove must be set up so that the stove itself, the flue pipe, and the chimney can all be cleaned.

### Position near to non-flammable walls

When positioning near a non-flammable wall, we recommend you keep a minimum distance of 50 mm between the rear of the product and the wall for cleaning purposes.

### Distance to flammable walls

#### 45° Corner installation

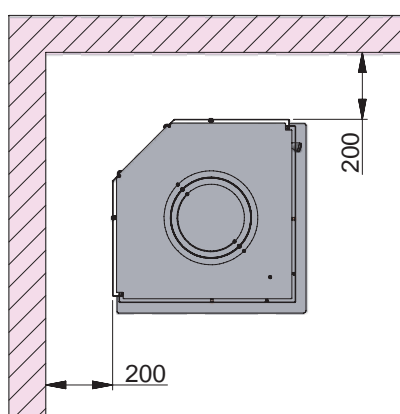

#### Parallel rear wall installation

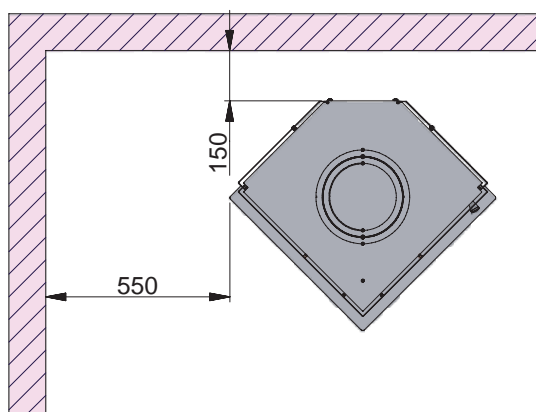

### Distance to furniture: 1000 mm

But please check to avoid furniture or other furnishings being dried out due to being too close to the stove.

### Connection between stove and steel chimney

Your Scan dealer, or local chimney sweep, can advise you on choosing a make and type of steel chimney. This ensures that the chimney will match your wood-burning stove. As a general rule, the length of the flue should not be less than 3.5 m measured from the top of the wood-burning stove.

Choosing the wrong length or diameter of steel chimney could impair functionality.

Always observe the chimney vendor's instructions precisely.

### Requirements for chimney

The chimney must be labeled T400 and G for soot testing.

### Preparing the stove for top/side/rear outlet

To connect the flue pipe, remove the required cover plate as follows:

1. Use the tools provided (see service package) to remove the cover plate at the rear of the wood-burning stove.
2. Tilt the cover plate back and forth a number of times to loosen the plate before removing it.

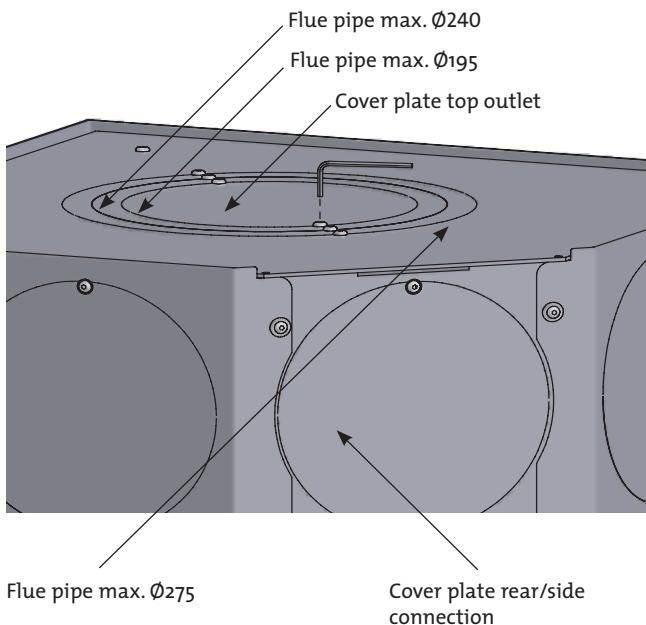

### Connection with 90° elbow pipe (top outlet)

If you intend to use a 90° elbow pipe to connect the wood-burning stove, the cleansing lid on the elbow pipe must be in the vertical section of the pipe to allow cleaning of the horizontal section through the access cover.

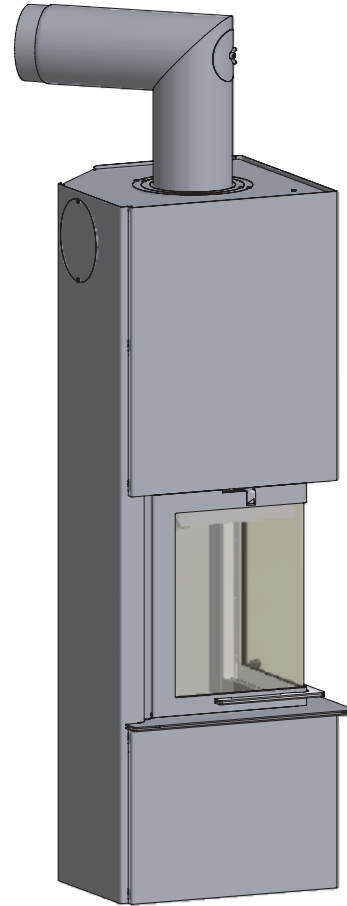

### Connection for rear/side outlet

For installation through rear or side walls, we recommend a 2x45° elbow pipe with cleansing lid to facilitate cleaning of the smoke gas pipe. Keep a distance of 160 mm between the center of the rear/side outlet and the bottom of the elbow pipe.

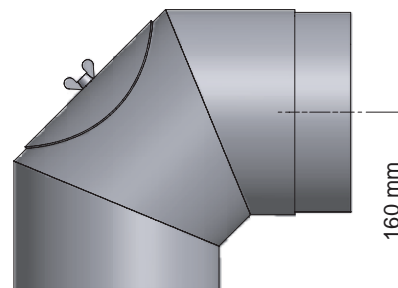

## Flue pipe with damper

The wood-burning stove is provided factory side with a damper which we recommend be fitted in the flue pipe, see page 9 "Using your stove in various weather conditions".

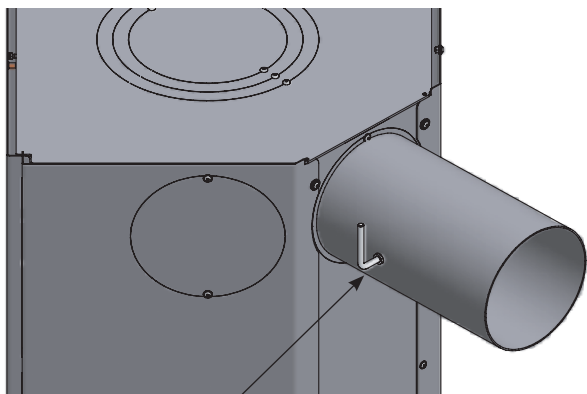

Flue pipe with damper fitted

## Fitting the damper

To fit the damper, holes are drilled in the flue pipe. Tension the spring to fix the damper in the required position. We recommend setting the damper to fully open position.

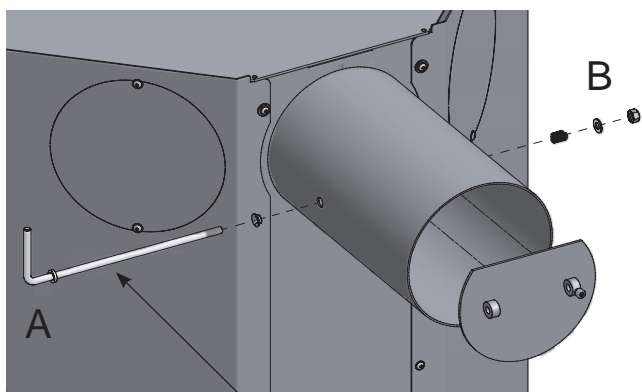

Fitting the damper

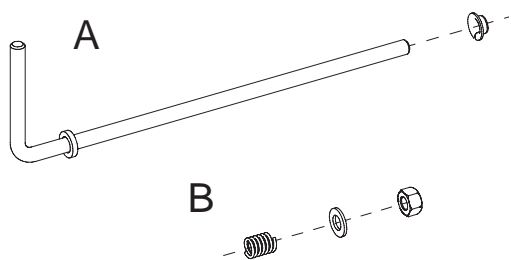

## Fresh air intake

In a well-insulated house, the air used up by the burning process has to be replaced. This particularly applies to houses with mechanical ventilation. There are different ways of making sure that an air exchange takes place. The most important thing is to ensure that there is a supply of air to the room where the wood stove is located. The external wall vent must be located as close to the wood stove as possible, and you must be able to close it when you are not using the wood stove.

National and local building regulations must be followed with regard to the connection of fresh-air intake.

## Fitting the fresh-air connection piece

The Scan DSA 10 can be connected using a fresh-air connection piece. Installation of the fresh-air connection piece is shown below.

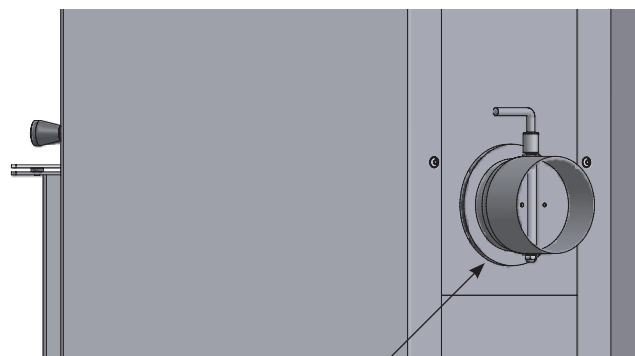

Connection piece

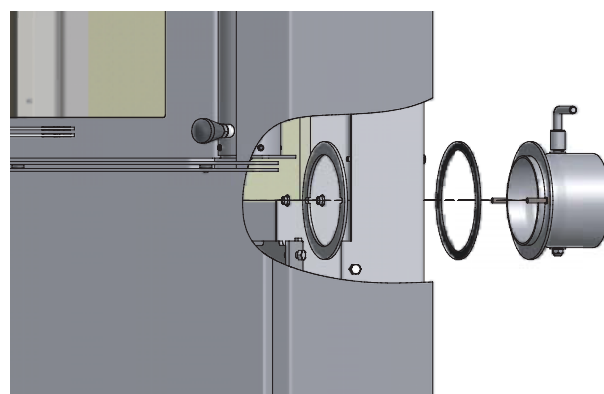

### CB Technology (Clean Burning)

Your wood-burning stove is fitted with CB technology. To ensure optimum burning of the gases released by the burning process, air is guided by a specially developed system. Pre-heated air is fed into the combustion chamber through the small holes below the smoke deflector plate. The airflow is driven by the combustion speed, and cannot be regulated.

### Combustion air

Combustion air is pre-heated and fed directly to the fire. At the same time, the combustion airflow cleans the glass plane to avoid soot build-up. If you over-restrict the combustion airflow, soot can build up on the glass pane. Combustion air defines the heating output of the wood-burning stove.

Setting for normal load: 20%

### Smoke deflector plates

The smoke deflector plates are located in the upper part of the combustion chamber. The plates hold back smoke, making sure it stays inside the combustion chamber for a longer time before escaping through the chimney. This reduces the smoke gas temperature as the gases have more time to dissipate heat to the wood stove. The smoke deflector plates must be removed for sweeping; see "Wood stove maintenance". Note that the smoke deflector plates are made of porous, ceramic material, and can break. Exercise care when working. The smoke deflector plates are subject to wear and tear, and are not covered by the warranty.

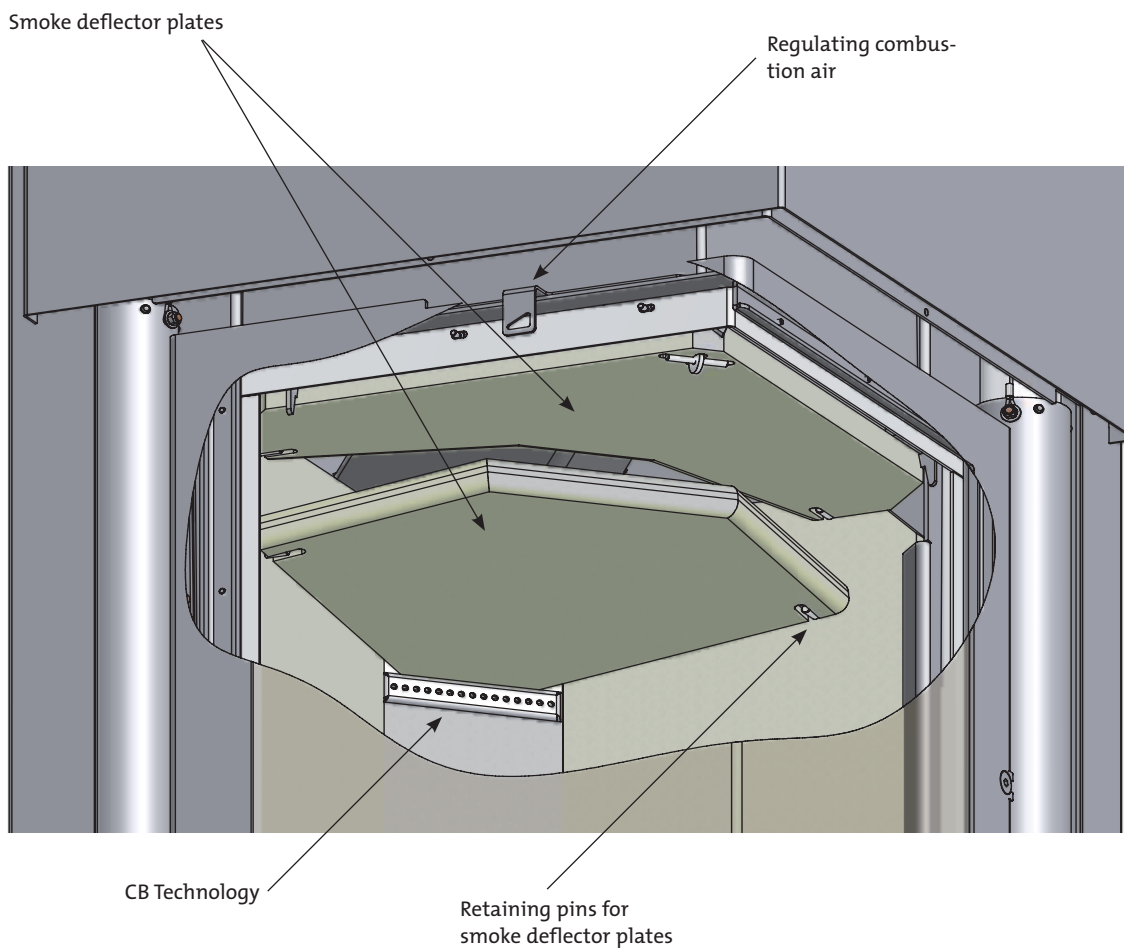



## Environmentally-Friendly Heating

Avoid restricting your wood-burning stove to an extent where no flames are visible during the degasifying period, as this leads to particularly inefficient heating. The gases released by the wood do not burn due to the low temperature in the combustion chamber. Part of the gas condenses in the wood-burning stove and flue system as soot, and this could lead to your chimney catching fire. The smoke that exits the chimney is bad for the environment and has an unpleasant smell.

## Lighting

We recommend the use of fire starters, or similar products, which are available from your Scan dealer. Using fire starters helps to light the wood quicker, and keeps the burning process clean. Never use liquid lighting fuels!

## “Top down” lighting

2 logs approx. 30 cm long with a weight of approx. 1.0 – 1.3 kg per piece.

1 log approx. 25 cm long with a weight of about 0.5 kg.

8 - 16 kindling sticks of about 20 cm with a total weight of approx. 400 g. 3 fire starters.

Position the large logs in the centre of the combustion chamber 1-2 cm apart as shown. Put half the kindling sticks across the logs in a criss-cross fashion. Place the smallest log on top of the sticks as shown and arrange the last sticks in front of the log. Position the firestarters between the sticks and light

Set the combustion airflow controls to maximum for about 20 - 30 minutes. When the two larger logs have caught fire properly, you can set the combustion airflow to the desired level.

Top down lighting gives a more environmentally friendly start to your fire and helps to keep the glass areas as clean as possible.

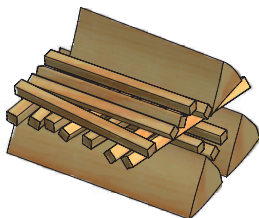
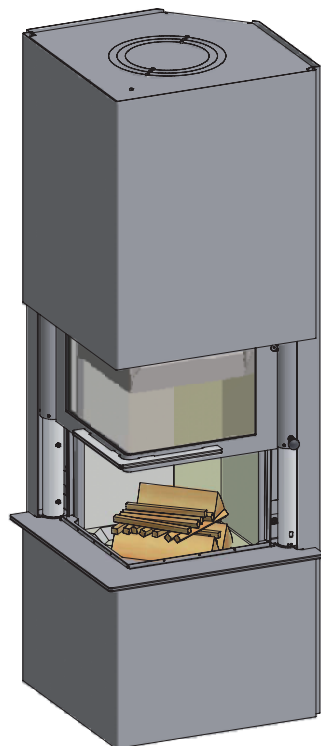

## Continuous firing

It is important to reach as high a temperature as possible in the combustion chamber. This makes the most efficient use of the wood-burning stove and fuel, and ensures a clean burning process. At the same time, this avoids soot build-up on the combustion chamber walls and glass. While the stove is lit, you should not see any smoke, but just air movement that indicates the burning process.

After completing the lighting phase, you should have a good layer of embers in the woodstove; you can then start stoking up the stove. Lay 2 logs, of about 1.0 - 1.2 kg weight with a length of about 30 cm onto the fire.

Note! The wood must catch fire quickly; this is why we recommend setting the combustion airflow to full power. Running the stove at too low a temperature and with too little combustion air can lead to deflagration of the gases, and thus cause damage to the stove.

When stoking up with wood, always open the glass door carefully to avoid smoke escaping. Stoke up with wood while the fire is still burning nicely. If it seems that the woodstove is burning your fuel too quickly, you can adjust the damper in the flue pipe (see page 7).

## Using your stove in the spring or autumn

Occasional lighting of the stove using the “top down” lighting method is recommended in changeable weather such as in spring/autumn when your heating requirements are not as great.

## Heating with open door

Note that your wood-burning stove was not designed for continuous heating with the door open, as this mode of operation will mean inefficient burning, poor heating performance, and higher emission levels.

However if you do leave the wood-burning stove door open during use, note that smoke may escape from the stove into the room where the stove is located. The reason for this is that the smoke temperature at the top of the chimney is lower than the ceiling temperature in the room where the stove is located, and this causes lower pressure in the room than in the chimney. Smoke may thus be drawn into the room. Whether or not smoke actually escapes into the room depends on your chimney design. Try heating the stove with the door open in different weather conditions. If no smoke escapes into the room, your installation is excellent. But if smoke escapes from the wood-burning stove into the room, make sure you fit a smoke extractor to the chimney to avoid smoke build-up in the room where the stove is located.

## Why you need a chimney

The chimney is the wood-burning stove's motor; its performance decides how well your stove will work. The draft in the chimney creates a vacuum in the wood-burning stove. The vacuum draws the smoke out of the stove, and takes in air through the combustion air baffle to fuel the burning process. Combustion air is also used for the airwash system that keeps the window clear of soot.

The draft in the chimney is caused by the difference in temperatures inside and outside the chimney. The higher the temperature difference is, the better the draft in the chimney will be. It is thus important for the chimney to reach operating temperature before you adjust the damper to restrict combustion in the stove (a brickwork chimney will take longer to reach operating temperature than a steel chimney). It is very important to reach operating temperature as quickly as possible on days on which the draft in the chimney is poor due to unfavorable wind and weather conditions. Make sure the fuel ignites as quickly as possible (with visible flames). Chop the wood into particularly small pieces; use an extra fire lighter etc.

After longer periods of disuse, check the chimney flue for blockage. You can connect several units to the same chimney. But make sure check with your chimney sweep to observe local regulations.

No matter how good your chimney is, it will not perform well if you do not use it correctly. On the other hand a poor chimney, may give you acceptable results if you use it correctly.

### Using your stove in various weather conditions

Wind blowing on the chimney can have a great effect on how your stove reacts in various wind conditions; you may need to adjust the airflow to achieve good burning results. Fitting a damper in the flue pipe may also help as it will give you the ability to regulate the draught in changing wind conditions.

Fog can also have a great influence on how well a chimney draws; you may again need to adjust the airflow settings to achieve good burning results.

### General Notes

Your wood stove is not designed for continual heating for periods of over 24 hours.

Please note! Parts of the wood-burning stove, especially the outer surfaces, become hot during use. Please exercise due care.

Never empty ashes into a flammable container. Ashes can contain glowing embers long after you finish using your wood stove.

While the stove is not in use you can close the damper to avoid drafts through the stove.

After longer breaks you should check the smoke outlet paths for blockages before lighting.

### Chimney fire

In the case of a chimney fire, keep the door and all dampers on the wood-burning stove closed. If necessary, call the fire brigade.

## Handling fuels

### Selecting Wood/Fuel

You can use any type of wood as firewood, however, harder types, such as beech, ash, are generally better for heating as they burn more evenly and create less ash. Other wood types like maple, birch and spruce are excellent alternatives.

### Handling

Firewood is best if you fell the tree, and saw and split the wood, before May 1st. Remember to cut the logs to match the size of your wood-burning stove's combustion chamber. We recommend a diameter of 6-10 cm. The length should be about 6 cm shorter than that of the combustion chamber to leave enough space for air to circulate. Firewood with a greater diameter needs splitting. Split wood dries faster.

### Storing

You need to store the sawn and split firewood in a dry place for 1-2 years before burning. Wood dries faster if you stack it in an airy place. Before use, store the firewood for a few days at room temperature. Note that wood absorbs moisture during the autumn and winter seasons.

### Moisture

To avoid environmental issues, and for optimum burning, wood has to be perfectly dry to be suitable for use as firewood. The max. residual moisture in the wood should not exceed 21%. A moisture content of 15-18% yields best results. As an easy way of checking if wood is dry, just knock two pieces of wood together. If the wood is moist, the sound will be dull.

If you use damp wood, most of the heat it produces will be used to evaporate the water. The temperature in the wood stove does not rise, and the room is not sufficiently heated. Of course, this is not economical, and it will cause soot build up on the glass pane, in the stove, and in the chimney. Burning moist wood also causes pollution.

### Understanding units for measuring wood

Various units of measurement are used for wood. Before you buy wood, it makes sense to familiarise yourself with the terms. There are various brochures, in public libraries for example, that cover this topic.

### Use of the following as fuel is illegal

Painted, pressure impregnated, or glued wood, driftwood from the sea. Never burn chipboard, plastics, or chemically treated paper. These materials are dangerous to humans, to the environment, your wood stove, and your chimney. To keep a long story short – make sure you burn only quality firewood.

### Firewood fuel value

The fuel value is different for different types of wood. In other words, you need to use more wood of certain types to achieve the same heating performance. This Instruction Manual assumes that you will be using beech, which has a very high fuel value, and is also a wood that is easy to procure. If you use oak or beech wood fuel, note that these wood types have a greater fuel value than, say, birch. Make sure you use less fuel to avoid damage to the wood-burning stove.

| Wood types | Kg Dry wood /m <sup>3</sup> | Compared to beech |
|------------|-----------------------------|-------------------|
| Hornbeam   | 640                         | 110%              |
| Beech/Oak  | 580                         | 100%              |
| Ash        | 570                         | 98%               |
| Maple      | 540                         | 93%               |
| Birch      | 510                         | 88%               |
| Pine       | 480                         | 83%               |
| Fir        | 390                         | 67%               |
| Poplar     | 380                         | 65%               |

## Maintaining your wood-burning stove

Apart from regular chimney sweeping, your wood-burning stove does not require any regular maintenance.

### Coated surfaces

Clean your wood-burning stove by dusting with a dry, lint-free cloth.

If the topcoat is damaged, you can purchase a repair spray from your authorised Scan dealer. As slight differences in colour are possible, spray a larger area to achieve a natural transition for best results. For best results, apply repair spray when the wood-burning stove is hand-hot.

### Cleaning the glass

Our wood-burning stoves are designed to prevent serious soot build up on the glass. The best way to achieve this is to make sure you have a sufficient combustion air supply. It is also important to use dry wood, and have a correctly dimensioned chimney.

Even if you follow all of our instructions, a slight film of soot can build up on the glass.

Before cleaning the glass, lock the door in the top position using the fastener.

Then open the door as follows:

use the special tool included with your stove to release the screw on the door as shown below. Carefully lift and open the door. You can easily remove the sooty build up by cleaning with a dry cloth and glass cleaner. Your authorised Scan dealer stocks a special glass cleaner for this purpose.

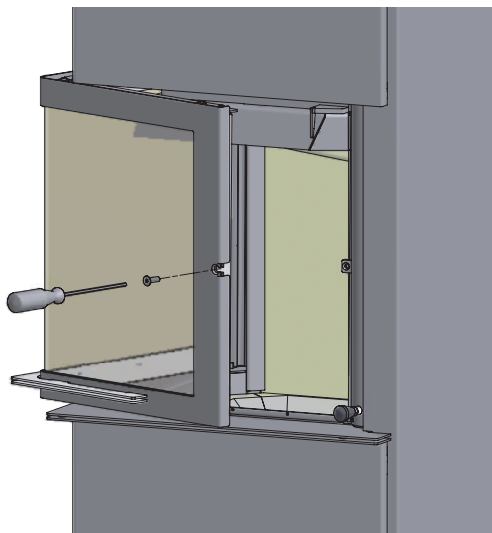

### Combustion chamber lining

Slight cracks can appear in the combustion chamber lining due to moisture, or to the heating/cooling process. These cracks have no influence on the heating performance or lifetime of your stove. However, if the lining starts to crumble, you must replace it. The combustion chamber lining is not covered by the warranty.

### Seals

All wood-burning stoves have seals made of ceramic material fitted to the stove, the doors, and/or the glass. These seals are subject to wear and tear, and must be replaced when necessary.

## Chimney sweeping and cleaning your wood-burning stove

Follow national and local chimney sweeping regulations. We recommend having the wood-burning stove cleaned regularly by the chimney sweep.

Before starting to clean your wood-burning stove, and sweep the flue pipe, we recommend first removing the smoke deflector plates. Use only original replacement parts for maintenance and repairs of your stove.

Note! Make sure the stove is cold before starting maintenance or repair work.

### Removing the smoke deflector plates

Lift the lower smoke deflector plate, remove the pins at the sides, and then remove the plate. Remove the upper smoke deflector plate in the same way.

### Smoke escaping

- Damp wood
- Chimney not drawing properly
- Chimney is not properly dimensioned for the stove
- Check if the smoke gas pipe/chimney are blocked
- Is the chimney the right height for its surroundings?
- In case of rear outlet, check that the smoke gas pipe does not reach into the chimney core pipe
- Vacuum in room
- The door is opened before the embers have burned down sufficiently

### Wood burning too quickly

- The air valves are set incorrectly
- The smoke deflector plates is incorrectly mounted or missing
- Inferior firewood (waste wood, pallets etc.)
- Chimney too large

### Soot build-up on glass

- not enough combustion air
- damp wood
- wood pieces too large on lighting
- inferior firewood (waste wood, pallets etc.)
- chimney not drawing sufficiently
- vacuum in room

### Excessive soot build-up in chimney

- poor burning (more air required)
- damp wood

### The surface of the stove is turning grey

- overheating (see instructions for heating)

### Poor heating performance of stove

- damp wood
- not enough wood
- inferior wood quality with low fuel value
- smoke deflector plates are not fitted correctly

### Odour and sound coming from the stove

- The lacquer on the stove hardens when you use the stove for the first time; this can cause an odour. Open a window or a door for ventilation, and make sure the stove is heated up sufficiently to avoid odours later.
- When heating up and cooling down, the stove may make some clicking noises. These are due to the huge temperature differences to which the material is exposed and do not indicate any product defects.

### Warranty

All wood-fired Scan products are made of high-quality materials and subject to strict quality controls before leaving the factory. We give a warranty of 5 years on manufacturing errors or defects.

You must quote your stove's product registration number when you contact us or your authorised Scan dealer with a warranty claim.

The warranty covers all parts which in the opinion of Scan A/S require repair or replacement due to manufacturing or construction error

The warranty applies to the original purchaser of the product only, and is not transferable (except on prior sale).

The warranty covers only damage caused by manufacturing or construction errors.

### The following parts are not covered by the warranty

- Wear and tear parts, such as the combustion chamber liners, smoke deflector plates, shaker grate, glass, tiles, and seals (except for defects which were present on delivery).
- Defects caused by external chemical and physical influences during transportation, storage and assembly, or at a later time.
- Soot build-up caused by poor chimney draught, damp wood, or improper use.
- Costs of additional heating in connection with a repair.
- Transport costs.
- Costs for setting up, removing the wood-burning stove.

### This warranty is void

- In case of incorrect installation (the installer is responsible for observing and complying with legal requirements and local bylaws, along with this Assembly- and Instructionsmanual for the wood-burning stove and accessories).
- In case of improper use, and/or use of prohibited fuels, non-original spares (see this Assembly- and instructions manual).
- If the product registration number of the stove has been removed or damaged.
- In case of repairs that do not comply with our instructions or instructions by an authorised Scan dealer.
- In case of any manipulation of the original state of this Scan product or its accessories.
- This warranty is only valid in the country to which this Scan product was originally supplied.

Always use original replacement parts, or parts recommended by the manufacturer.