

EU SCAN 5005 FRL

EU - ASSEMBLY AND INSTRUCTIONS MANUAL

SCAN 5005 FRL



SCAN®

ASSEMBLY AND INSTRUCTION MANUAL SCAN 5005 FRL

EU SCAN 5005 FRL

CONGRATULATIONS ON YOUR NEW SCAN BUILT-IN STOVE

You have purchased a product by one of Europe's leading manufacturers of wood-burning stoves, and we are sure that you will have years of pleasure from your purchase.

To make the best possible use of your stove, it is important that you follow our advice and instructions. Read through this Assembly and Instruction Manual carefully before you start to assemble your stove.

SCAN 5005 FRL

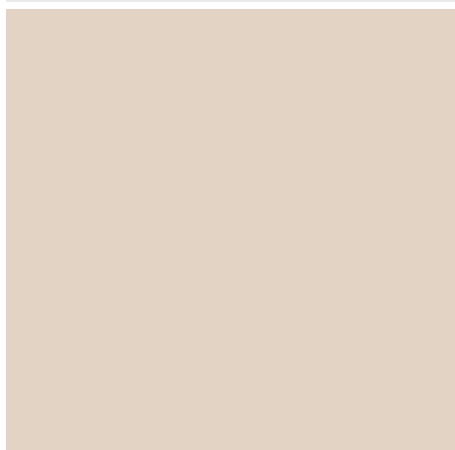
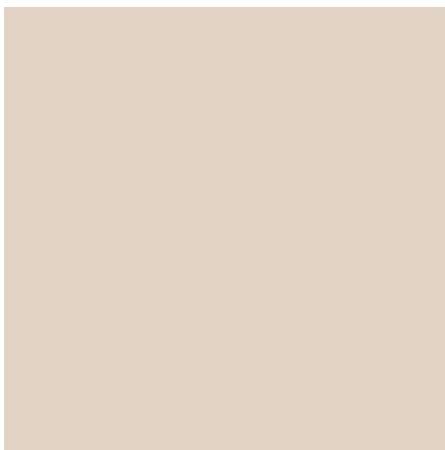

CONTENTS

TECHNICAL DATA	4		
Installation	4	Product registration number	8
Safety	4	Dimension sketch	9
Technical data	5	Minimum distances	11
Type plate	7		
ASSEMBLY	13		
Additional accessories	13	Using the handling set	15
Disposal of packaging	13	Before building the insert	15
Room requirements	13	Fresh air intake	16
Load-bearing foundation	13	Closed combustion system	16
Floor plate	13	Fresh air box for floor	16
Existing chimney and pre-fabricated element chimney	14	Door (Self-closing)	17
Connection between built-in stove and steel chimney	14	Mounting of the heat shields/convection covers	18
Requirements for chimney	14	Frames	20
Trim	14	Convection air	24
Internal installation in non-flammable material	14	Mounting of convection grate	24
Building in the stove at a fire wall	14	Detachable handle	25
Safety distance	14	Ash container with grate	26
INSTRUCTIONS FOR USE	27		
Baffle plates	27	Combustion air	27
INSTRUCTIONS FOR HEATING	28		
Environmentally-friendly firing	28	Firing in the spring or autumn	29
Lighting	28	The function of the chimney	30
Continuous operation	29	Chimney fire	30
Warning about over-firing	29	General notes	30
Using the stove in various weather conditions	29		
HANDLING OF THE FUEL	31		
Selecting wood/fuel	31	Moisture	31
Preparation	31	Use of the following as fuel is illegal	31
Storing	31	Calorific value of the wood	31
MAINTENANCE	32		
Sweeping the chimney and cleaning the stove	32	Gaskets	33
Checking the stove	32	Painted surfaces	33
Servicing	32	Disposal of stove parts	34
Combustion chamber lining	32	Cleaning the glass	34
TROUBLESHOOTING	36		
WARRANTY	37		

TECHNICAL DATA

INSTALLATION

- The house owner is responsible for ensuring that installation and assembly are in accordance with national and local building regulations as well as the information provided in this Assembly and Instructions Manual
- When you install any kind of fireplace or stove, you must inform the local building and housing authorities. In addition you are obliged to have the installation inspected and approved by a local chimney sweep prior to commissioning
- To ensure best-possible functionality and safety for your installation, we advise you to call a professional fitter. Your Scan dealer will be able to recommend a qualified fitter in your area. For information on Scan Dealers, please go to www.scan-stoves.com

SAFETY

Any changes made to the product by the dealer, fitter or user could result in the product and safety functions not functioning as intended. The same applies to the fitting of accessories or extra equipment not supplied by Scan A/S. This could also be the case if parts that are necessary for the operation and safety of the stove are dismantled or removed.



■ **PLEASE NOTE!**

YOU GET THE BEST USE OF
THE STOVE BY USING
A TOP-DOWN
LIGHTING METHOD

SEE
"INSTRUCTIONS FOR HEATING"



TECHNICAL DATA

Test in compliance with EN 16510*		
	Classification of appliance	Type BE
P_{nom}	Nominal heat output	10 kW
η_{nom}	Energy efficiency at nominal heat output	83 %
$\eta_{s, nom}$	Seasonal space heating energy efficiency at nominal heat output	73 %
EEl	Energy efficiency index	110
	Energy efficiency class	A+
	Fuel	Wood**
	Fuel length, maximum	500 mm
$M_{h, nom}$	Fuel consumption	2.8 kg/h
	Amount of fuel	2.8 kg
	Amount of fuel, maximum	3.7 kg
CO_{nom}	CO emission at 13% O ₂ at nominal heat output	0.09 % 1140 mg/Nm ³
$NO_{x, nom}$	NO _x emission at 13% O ₂ at nominal heat output	126 mg/Nm ³
OGC_{nom}	OGC emission at 13% O ₂ at nominal heat output	36 mg/Nm ³
PM_{nom}	Dust emission at 13% O ₂ at nominal heat output	28 mg/Nm ³
p_{nom}	Flue draught at nominal heat output	11 Pa
	Recommended sub-pressure in the connecting piece	18-20 Pa
	Required combustion air supply	24 m ³ /h
$T_{fg, nom}$	Flue gas temperature at nominal heat output	242 °C
$T_{s, nom}$	Temperature in the flue connecting piece at nominal heat output	289 °C
T class	Chimney designation	T400 G
$\varnothing_{f, g, nom}$	Flue gas mass flow at nominal heat output	8.1 g/sec
V_h	Standing air loss	0 m ³ /h
CON/INT	Continuous operation (CON)/Intermittent operation (INT)	INT***
	Reaction to fire classification	A1

* EN 16510 was carried out on the installation shown on page 10.

** Use only recommended fuels - designation I.

*** Intermittent operation in this context means normal use of a wood-burning stove. In other words, you should let the fire die down until only the embers are left before refueling.

TECHNICAL DATA

Basic technical data		
Materials		Stainless steel Galvanised sheet Cast iron Chamotte Robax glass
Surface treatment		Senotherm
d_{out1}	Connecting piece int. diameter for outside flue pipe	175 mm
d_{out2}	Connecting piece ext. diameter for outside flue pipe	200 mm
	Fresh air connection piece external diameter	150 mm
L	Overall dimensions (length)	958 mm
H	Overall dimensions (height)	1382 mm
W	Overall dimensions (width)	656 mm
m	Mass (weight)	280/320 kg
m_{chim}	Maximum load of a chimney the stove may carry	120 kg
s	Protective insulation: fire wall (Calcium silicate boards)	50 mm
	Area for ingoing convection air	500 cm ²
	Area for outgoing convection air	750 cm ²

Minimum distances to combustibile materials (insulated flue pipe)		
d_R	Back	100 mm
d_S	Front to sides	800 mm
d_{S1}	Stoveside to sides	75 mm
d_C / d_{C1}	Ceiling	300/300 mm
d_P	Front	800 mm
d_F	Front to the bottom front radiation area	0 mm
d_L	Front to the side front radiation area	0 mm
d_B	Below the bottom (not regarding feet)	0 mm
d_{B1}	Bottom edge of door to floor	315 mm
d_{non}	Minimum distances to non-combustible walls	50 mm

The safety distances are only valid if the stove is installed according to the instructions in this manual.

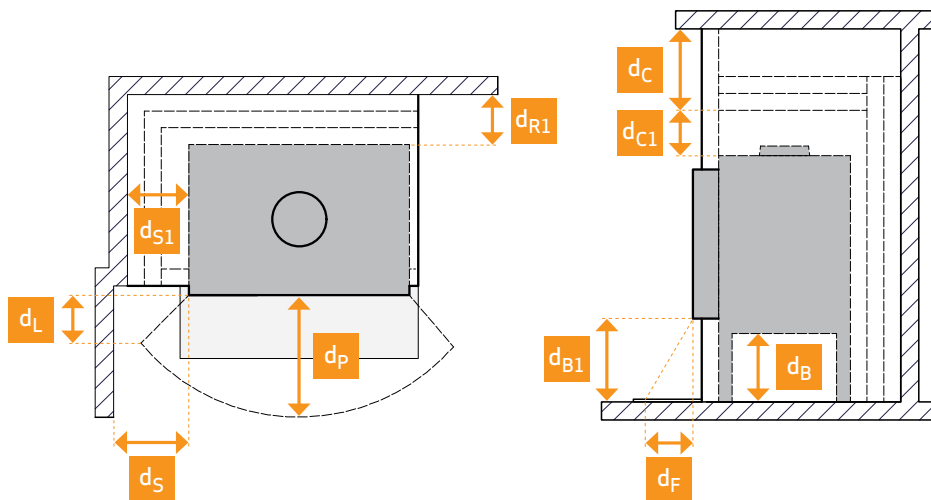

 This stove is produced in accordance with type approval for the product, which also covers the product’s Assembly and Instruction Manual. Read and follow the user operating instructions carefully.

The Declaration of Performance (DoP) is available from www.scan-stoves.com.

TYPE PLATE

All Scan wood-burning stoves are fitted with a type plate that specifies the approval standards and the distance to flammable materials.

The type plate is located at the rear of the stove.

Type plate

1	Scan 5005 FRL		CE 19	9
2	Standard:		EN 16510-1:2022, EN 16510-2-2:2022	
3	Approved by:		SZÚ • NB no. 1015	
4	Classification of appliance:		Type BE	
5	Use only these recommended fuels:		Wood logs	
6	Manufacturer:		Scan A/S • DK • 5492 Vissenbjerg	
7	DOP:		95005600	
8	P_{nom}	10	kW	10 Insert fired by solid fuel The appliance cannot be used in a shared flue Read instruction manual for further information Only use recommended fuels - designation I
	D_{nom}	83	%	
	CO_{nom} (13 % O ₂)	1140	mg/m ³	
	NO_{xnom} (13 % O ₂)	126	mg/m ³	
	OGC_{nom} (13 % O ₂)	36	mg/m ³	
	PM_{nom} (13 % O ₂)	28	mg/m ³	
	p_{nom}	11	Pa	
	d_p	800	mm	
	d_{non}	50	mm	
	d_R	There is more than one way to install this fireplace. Safety distances depend on the framing you use. For details see instruction manual.		
	d_S			
	d_C			
	d_F			
	d_L			
	d_B			
	Serial number:		206B2F0002	11

TYPE PLATE EXPLANATION

- 1 Type and/or the model number or designation to enable the appliance to be identified
- 2 Applicable standards
- 3 Name of test centre/certification number
- 4 Classification of appliance
- 5 Recommended fuels
- 6 Manufacturer's name and address
- 7 DOP document number
- 8 Table of values:

P_{nom} - nominal heat output

P_{part} - part load heat output

N_{nom} - energy efficiency at nominal heat output

N_{part} - energy efficiency at part load heat output

CO_{nom} - CO emission at 13 % O₂ at nominal heat output

CO_{part} - CO emission at 13 % O₂ at part load heat output

NO_{xnom} - NO_x emission at 13 % O₂ at nominal heat output

NO_{xpart} - NO_x emission at 13 % O₂ at part load heat output

OGC_{nom} - OGC emission at 13 % O₂ at nominal heat output

OGC_{part} - OGC emission at 13 % O₂ at part load heat output

PM_{nom} - dust emission at 13 % O₂ at nominal heat output

PM_{part} - dust emission at 13 % O₂ at part load heat output

p_{nom} - flue draught at nominal heat output

p_{part} - flue draught at part load heat output

Minimum distances to combustible material:

d_R - back

d_S - sides

d_C - ceiling

d_P - front

d_F - front to the bottom front radiation area

d_L - front to the side front radiation area

d_B - below the bottom (not regarding feet)

- 9 CE mark of conformity - The digits indicate the year of issue of the certificate
- 10 Product specifications and instructions
- 11 Type plate number

PRODUCT REGISTRATION NUMBER

All Scan wood-burning stoves are provided with a product registration number. This is unique to your stove and may need to be referred to when you contact Scan A/S or your dealer, e.g. for service or ordering spare parts.

We recommend taking a picture of the type plate and saving it digitally, or writing the number down in a safe place – e.g. together with your housing documents.

Product registration number Scan 5005 FRL

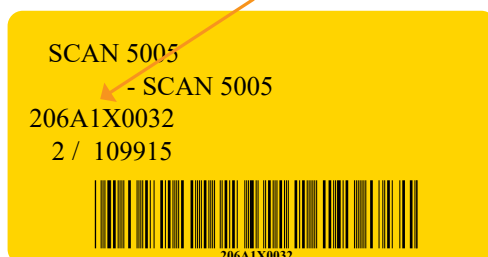

DIMENSION SKETCH

Scan 5005 FRL

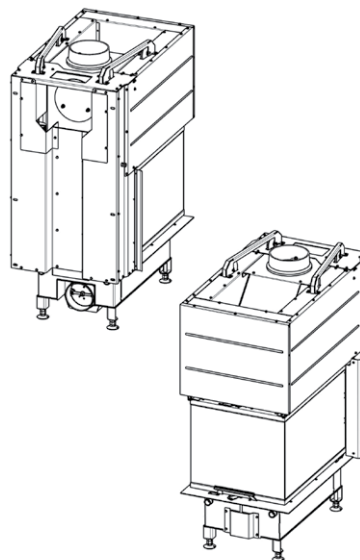
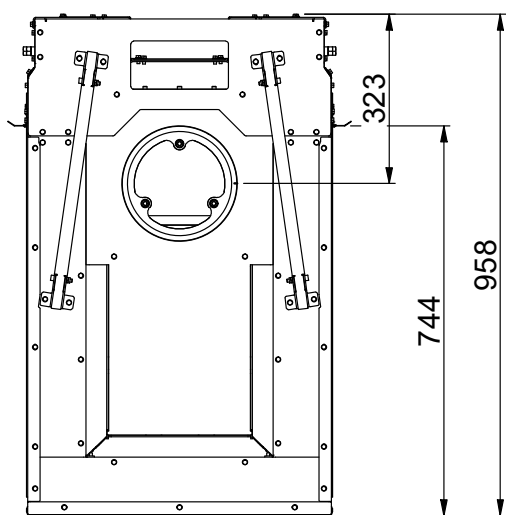
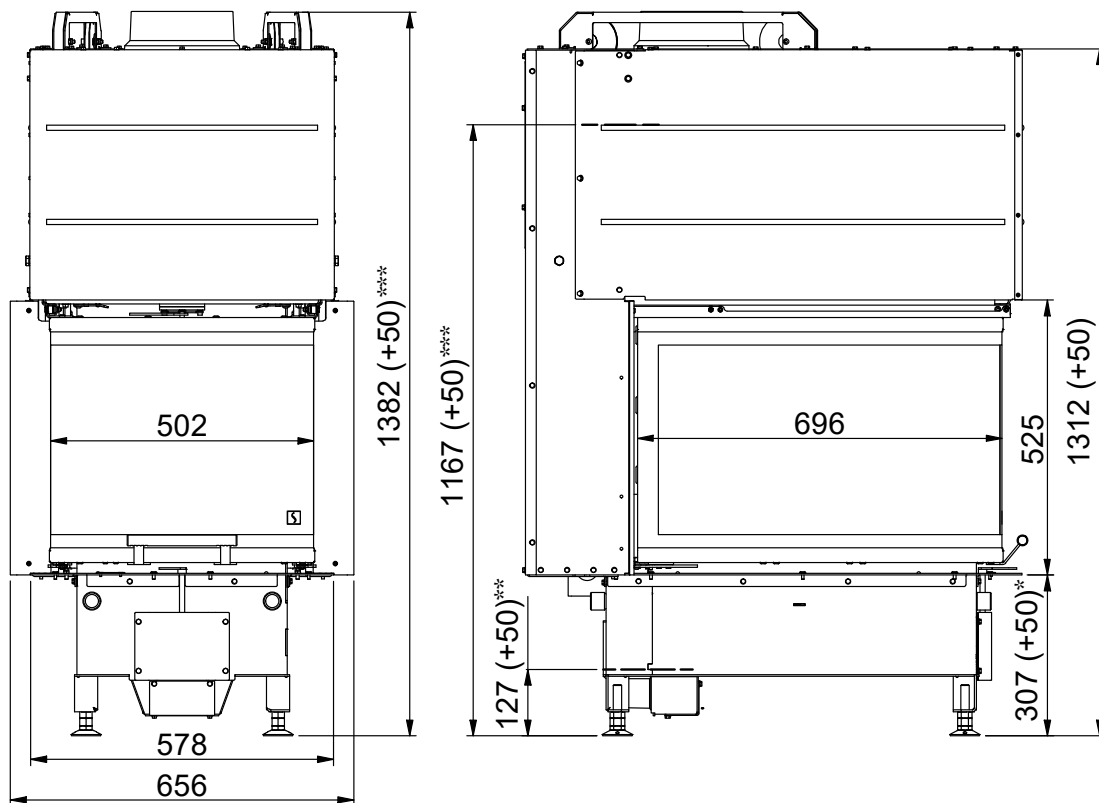

All distances are in mm.

All distances are minimum distances

*NB - remember to check the distance to flammable materials

** Connection of fresh-air intake \varnothing 150 mm

*** Height to the beginning of flue connecting piece at top outlet

DIMENSION SKETCH

Scan 5005 FRL with support construction*

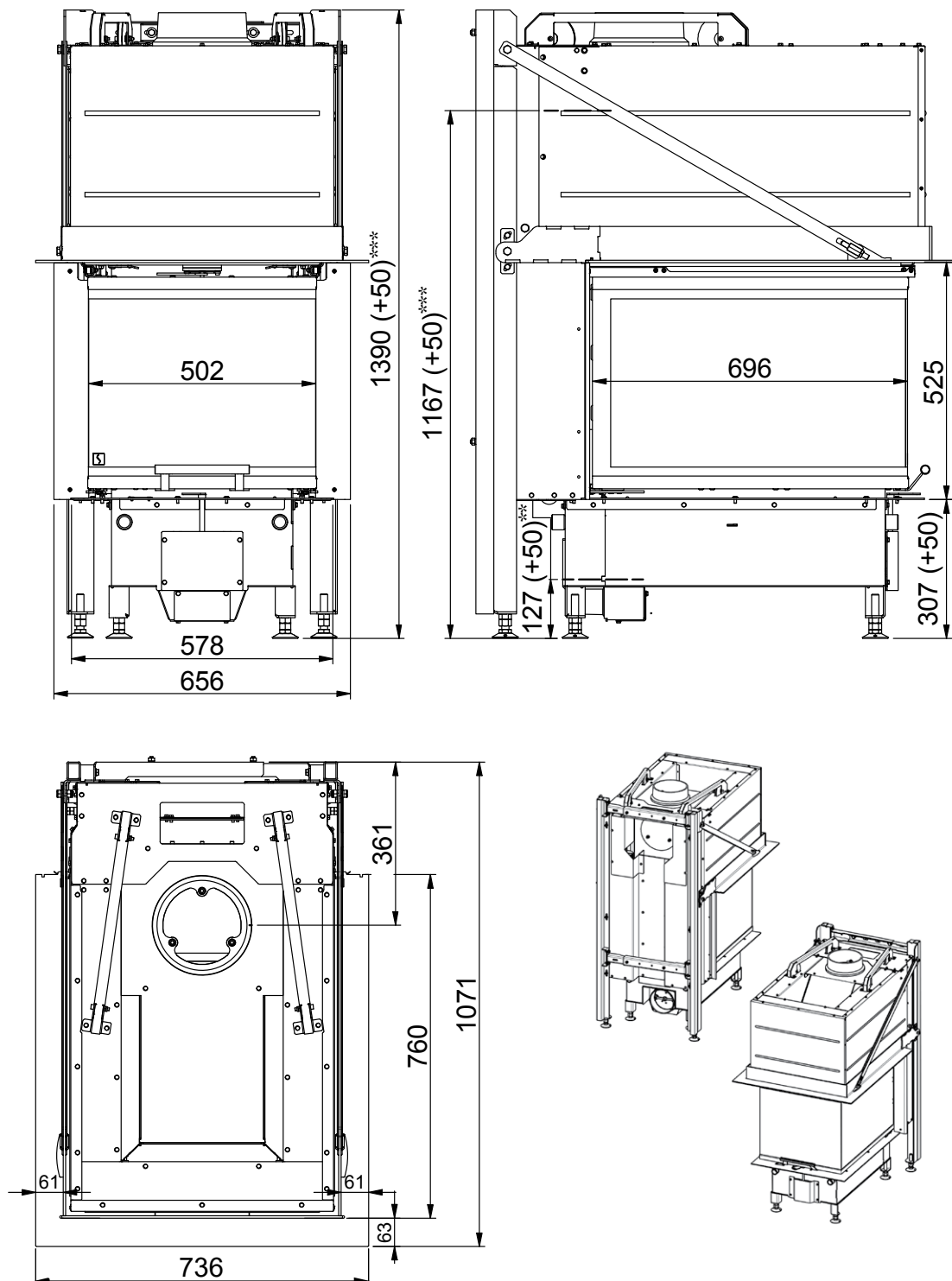

All distances are in mm.

All distances are minimum distances

* For heavy wall constructions or wide non combustible fireplaces, that are thicker than 50 mm

** Connection of fresh-air intake \varnothing 150 mm



*** Height to the beginning of flue connecting piece at top outlet

MINIMUM DISTANCES

Building in the Scan 5005 with radiation shields against a flammable wall protected by a fire wall

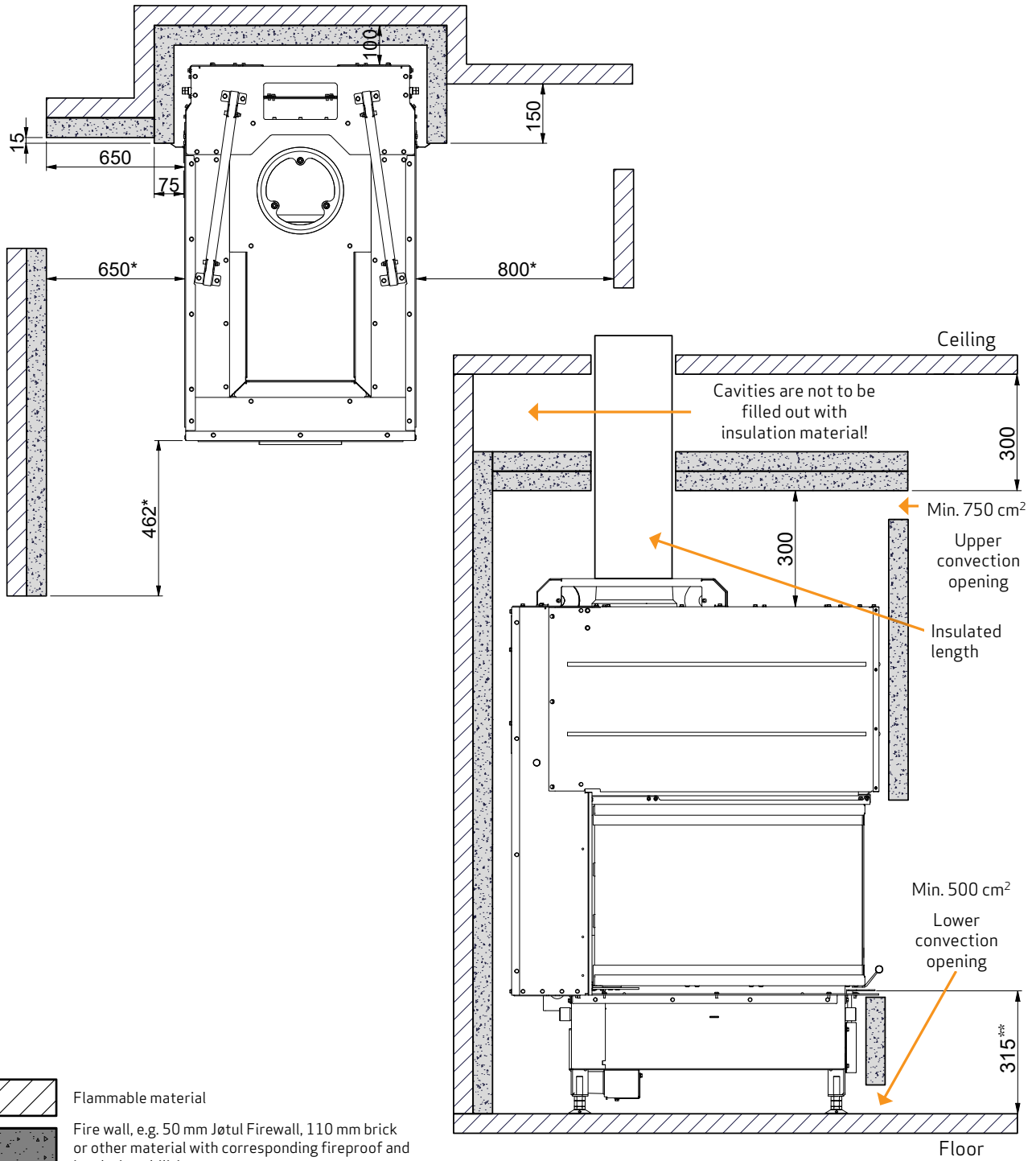
Installation with an insulated, vertical flue pipe
- structure/surround to ceiling





-  Flammable material
-  Fire wall, e.g. 50 mm Jøtul Firewall, 110 mm brick or other material with corresponding fireproof and insulating abilities

All distances are in mm.
All distances are minimum distances
These distances apply for an insulated flue pipe all the way down to the stove
* Distance to glass
** Distance to flammable floor

Building in the Scan 5005 with radiation shields against a flammable wall protected by a fire wall

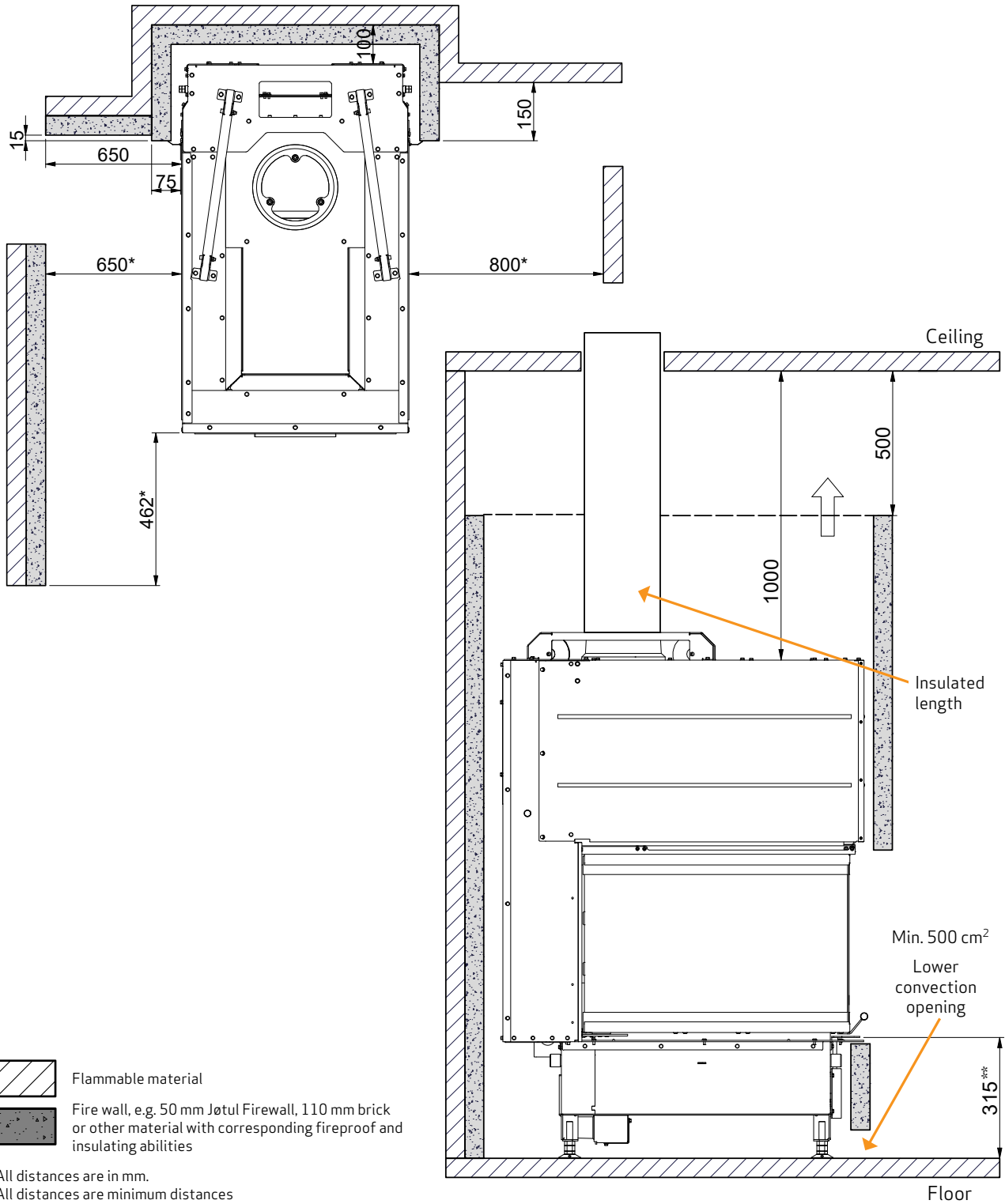
Installation with an insulated, vertical flue pipe
- open structure/surround



-  Flammable material
-  Fire wall, e.g. 50 mm Jøtul Firewall, 110 mm brick or other material with corresponding fireproof and insulating abilities

All distances are in mm.
 All distances are minimum distances
 These distances apply for an insulated flue pipe all the way down to the stove
 * Distance to glass
 ** Distance to flammable floor

ASSEMBLY

ADDITIONAL ACCESSORIES

- Handling kit (see page 15)
- Fresh air box Ø149 mm (see page 16)
- Frames (see page 20)
- White rear chamotte stone
- Black painted handle
- Ash container with grate (see page 25)
- Adjustable legs 190 mm
- Heat shield/convection cover (see page 18)
- Convection air grid (see page 24)
- White rear chamotte stone
- Detachable handle (see page 26)

DISPOSAL OF PACKAGING

Your Scan built-in stove may come supplied with the following packaging:

Wood packaging	The wood packaging can be reused and after final use can be incinerated as a CO ₂ neutral product or sent for recycling
Foam	Send for recycling or waste disposal
Plastic bags	Send for recycling or waste disposal
Stretch/plastic film	Send for recycling or waste disposal

ROOM REQUIREMENTS

The stove must be installed in rooms with a good ventilation. A good ventilation is vital for the efficient operation of your stove. We recommend installing smoke detectors in the home.

The distances specified in the manual only apply if you comply with the maximum amount of firewood. They only guarantee fire safety.

You should however assess whether furniture or other items might become excessively dry due to being too close to the stove. There is no guarantee that the present building materials can withstand the temperature in relation to visual changes.

- The stove is NOT to be built into flammable materials without the use of a fire wall and heat shields!
- Check that Building Regulations and any local by laws are followed during installation

LOAD-BEARING FOUNDATION

All items in our product range come under the category of lightweight fireplaces and stoves and do not normally require any reinforcement of the beam structure. They can be positioned on ordinary beams/floor.

You should of course make sure that the foundation on which the stove is positioned can indeed support the weight of the stove and, where applicable, a steel chimney, if you have opted for this solution. In case of doubt about the carrying capacity of the floor, please consult a building expert.

FLOOR PLATE

If you are placing the stove on a flammable floor, you must comply with the national and local regulations on the size of any non-flammable subsurface required to cover the floor around the stove.

Your local Scan dealer can advise you on regulations concerning protection of flammable materials in the vicinity of your stove.

The floor plate's function is to protect the floor and flammable material against any sparks that may occur.

EXISTING CHIMNEY AND PRE-FABRICATED ELEMENT CHIMNEY

If you intend to connect your stove to an existing chimney, it makes sense to contact an authorised Scan dealer, or a local chimney sweep, for advice. These experts will also let you know if your chimney needs renovating.

- When connecting a pre-fabricated element chimney, follow the manufacturer's connection instructions for the relevant chimney type

CONNECTION BETWEEN BUILT-IN STOVE AND STEEL CHIMNEY

Your Scan dealer, or local chimney sweep, can advise you on choosing a make and type of steel chimney. This ensures that the chimney will match your wood-burning stove.

REQUIREMENTS FOR CHIMNEY

The chimney must at least have a T400 designation, with G for the soot fire test. We recommend a chimney with a minimum internal diameter of 190 mm and a length of min. 5 metres.

If you opt to connect the built-in stove with an elbow pipe, you should use a curved elbow, as this gives a better draught.

If you connect the stove with a sharp elbow pipe, the cleansing lid must be placed in the vertical part so that the horizontal part can be cleaned through here.

If the chimney is fitted with a smoke extractor, it must be possible to adjust it to a suitable draft.

The appliance should not be installed in a shared flue.

The requirements to the chimney and the flue pipe in terms of safety distances must be met. The chimney shall be proven according to EN 13384-2:2015+A1:2019 depending on the individual situation on site.

- Choosing the wrong length or diameter of chimney could impair functionality
- Always comply exactly with the instructions provided by the chimney supplier

TRIM

The trim is mounted, when the surfaces of the covering are finished.

INTERNAL INSTALLATION IN NON-FLAMMABLE MATERIAL

When building or fitting into structures that do not contain flammable materials, a minimum distance of 50 mm must be maintained between the brickwork and the convection hood. This is to prevent cracks in the brickwork caused by the expansion of the metal while the stove is heating.

BUILDING IN THE STOVE AT A FIRE WALL

We refer to the building sketches on page 11-12.

SAFETY DISTANCE

European, national and local regulations concerning safety distances for wood-burning stoves and flue pipes must be complied with.

The stove must be set up so that the stove itself, the flue pipe, and the chimney can all be cleaned.

USING THE HANDLING SET (ACCESSORY)

You can buy a handling kit as an accessory.
Install the four tubes through the holes in order to lift the built-in stove.

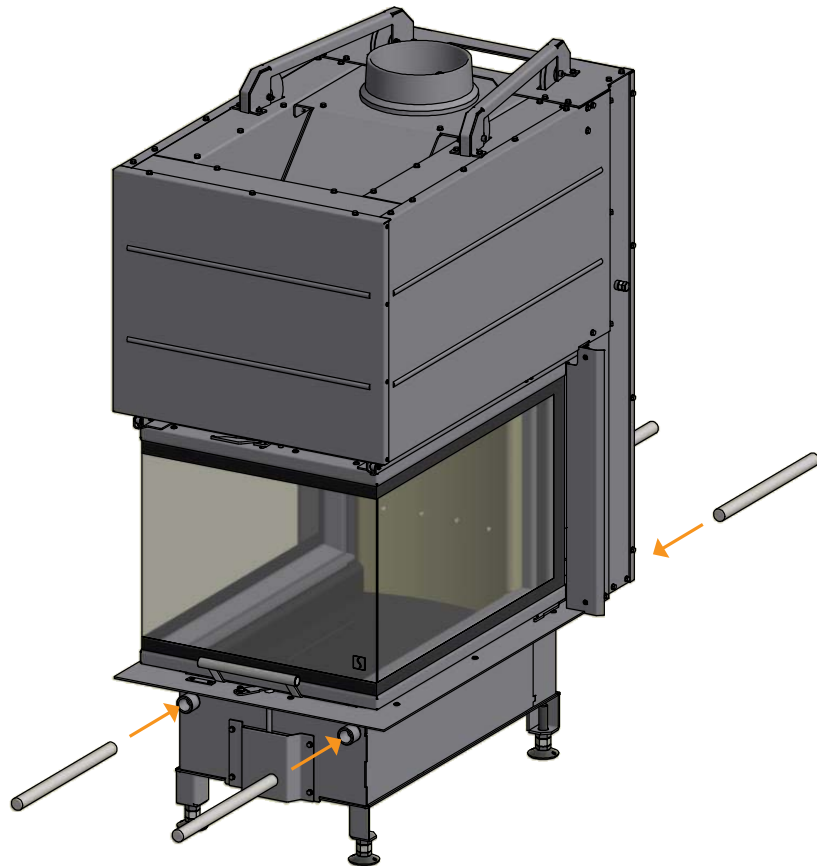

BEFORE BUILDING THE INSERT

IMPORTANT! Before the insert is built in, the bolts in each the side of the insert should be removed.

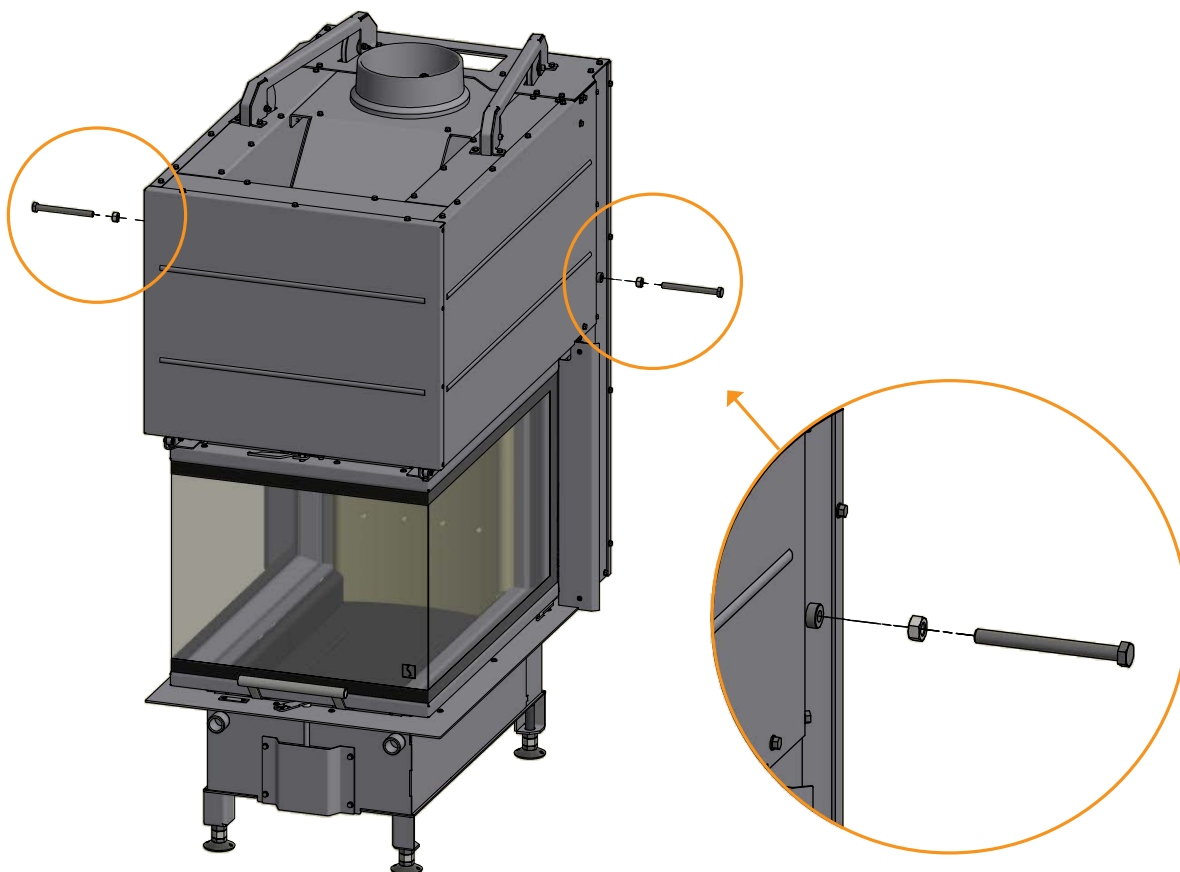

FRESH AIR INTAKE

In a well-insulated house the air used for the combustion process has to be replaced. This particularly applies to houses with mechanical ventilation. There are different ways of making sure that air is exchanged. The most important thing is to ensure that there is a supply of air to the room where the built-in stove is located. The external wall vent must be located as close to the stove as possible, and you must be able to close it when you are not using the stove.

National and local building regulations must be followed with regard to connection of a fresh air intake.

CLOSED COMBUSTION SYSTEM

You should use the closed combustion system for the built-in stove if you live in a newly-built, airtight home. External combustion air is connected through a ventilation pipe via the wall or floor.

We recommend mounting a valve in the ventilation pipe in order to avoid condensate in the stove and the pipe system, which can be closed when the oven is not in use. It can also be an advantage to insulate the ventilation pipe.

Minimum \varnothing 150 mm ventilation pipe, maximum length: 6 metres with a maximum of one bend. We recommend smooth steel pipes.

NOTE: If the stove has a fresh air connexion or closed combustion, the ventilation pipe must be open, when the stove is in use!

NOTE: If the combustion air is taken from a prefabricated chimney with integrated air vent, you must assure that there is a free area of min. 180 cm² between the inner core and the outer section.

FRESH AIR BOX FOR FLOOR (ACCESSORY)

A fresh air box is available as an accessory. For this box, you need a connection pipe (\varnothing 150 mm) which can be purchased in most D.I.Y.-stores.

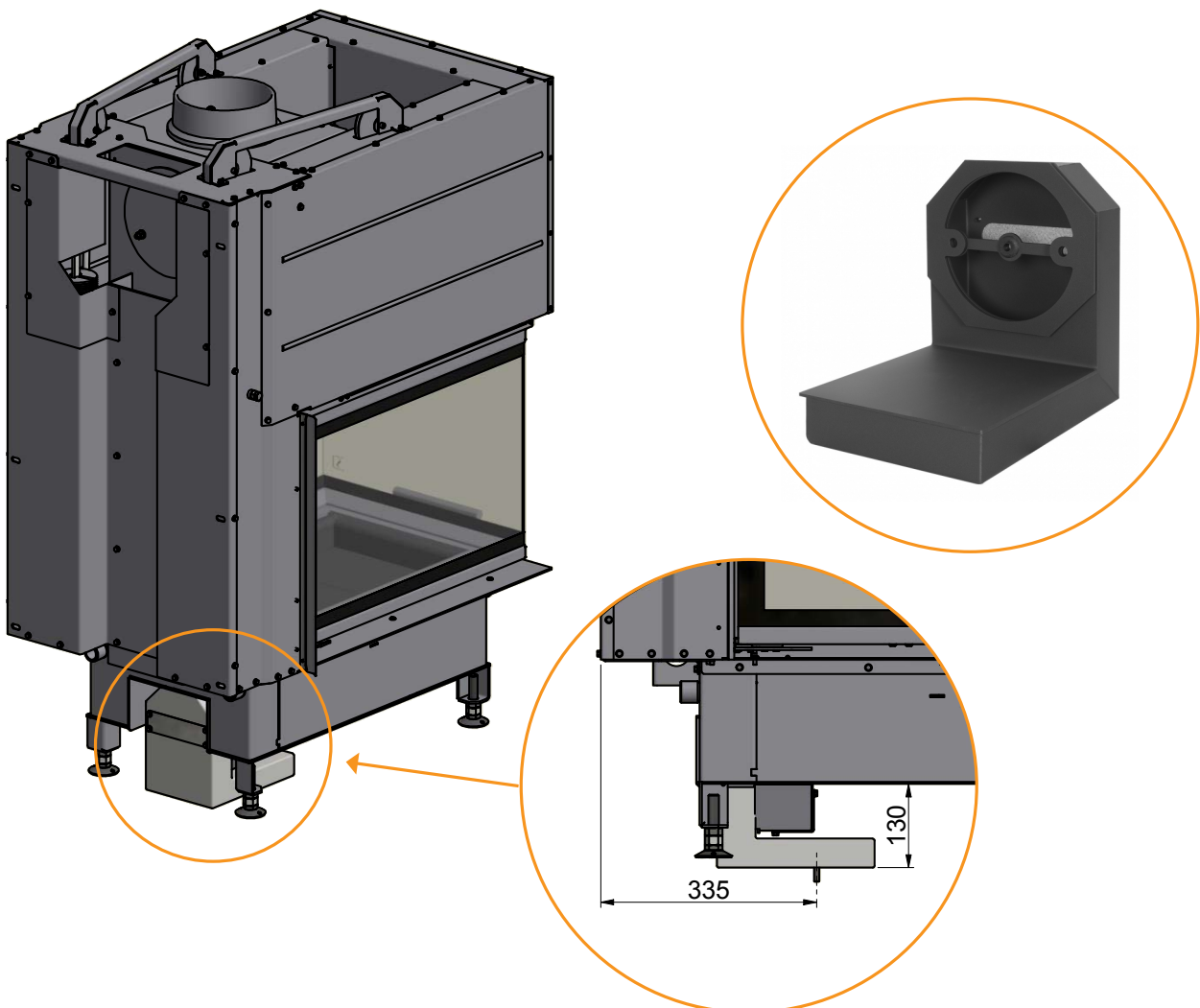

DOOR (SELF-CLOSING)

The door is delivered without self-closing function (Bauart 1). If you want a self-closing door, you can remove a disc from the counterweight.

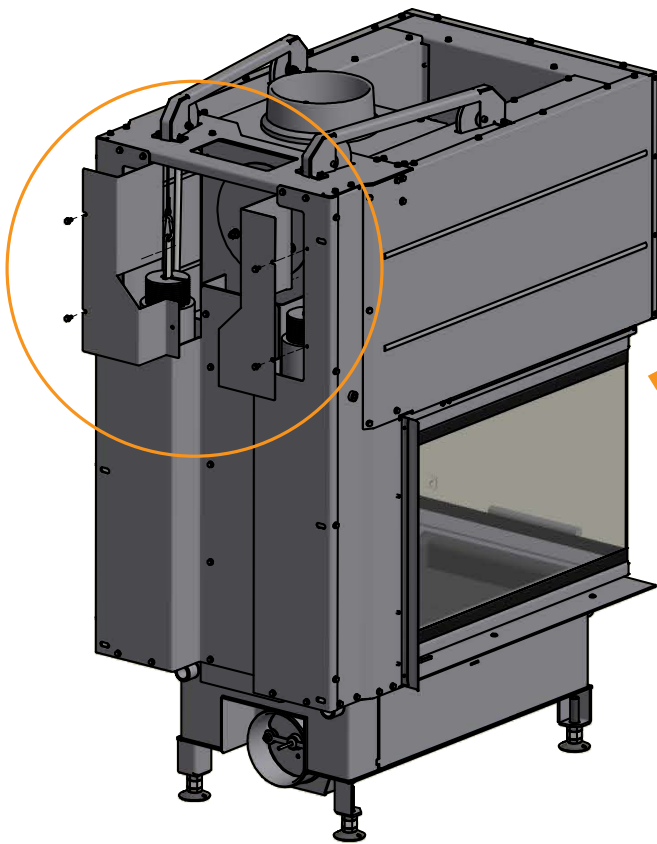

1

First remove the screws and the cover plates at the rear of the fireplace.

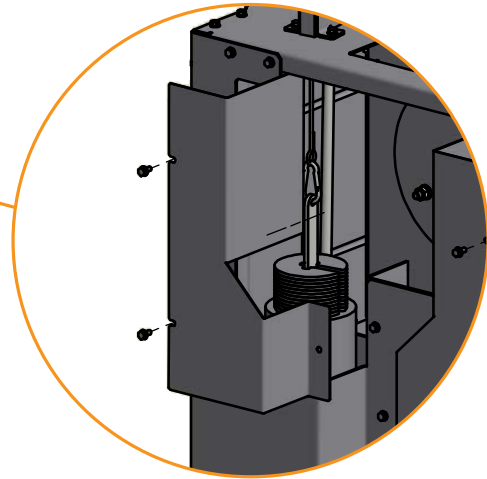

2

Remove the disc from the counterweight.

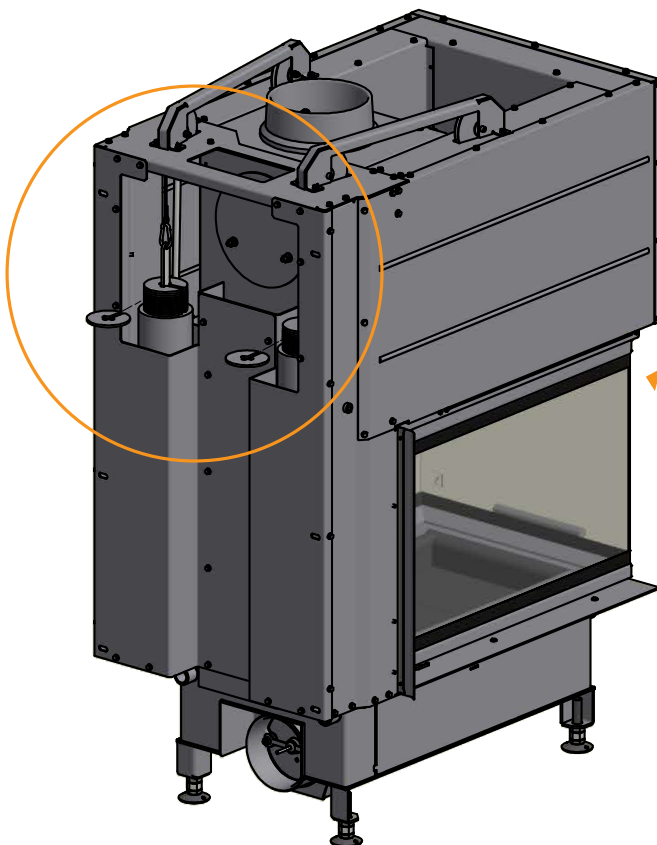

3

Remount the cover plates with the screws.

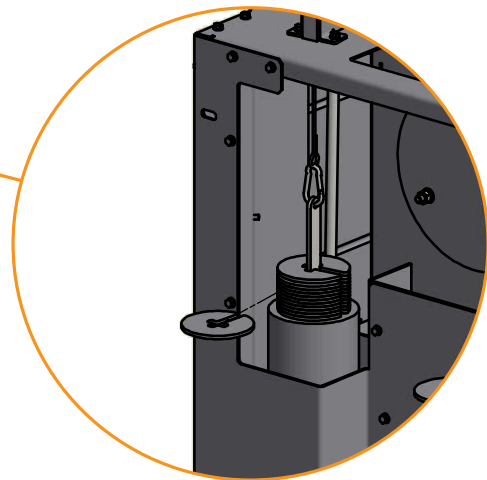

MOUNTING OF THE HEAT SHIELDS/CONVECTION COVERS (ACCESSORY)

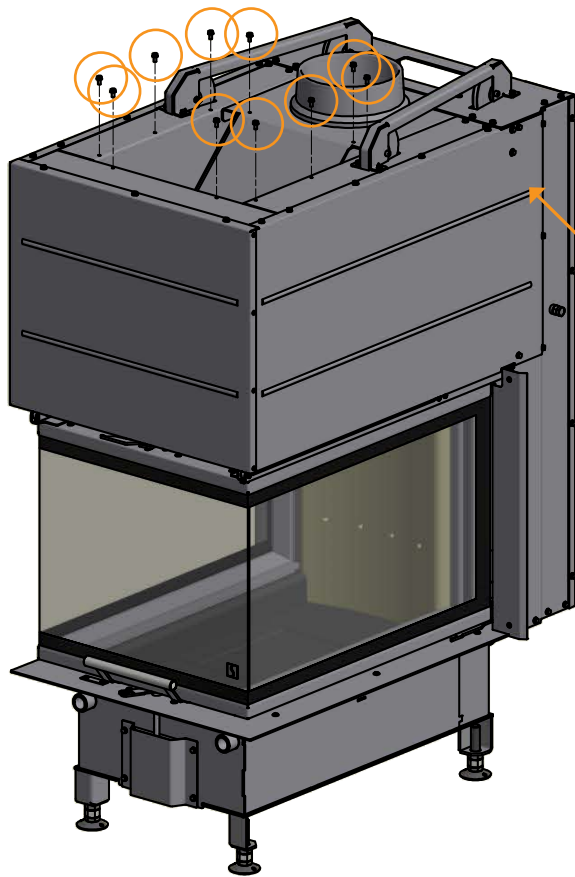

1

Dismount the screws on top of the fireplace

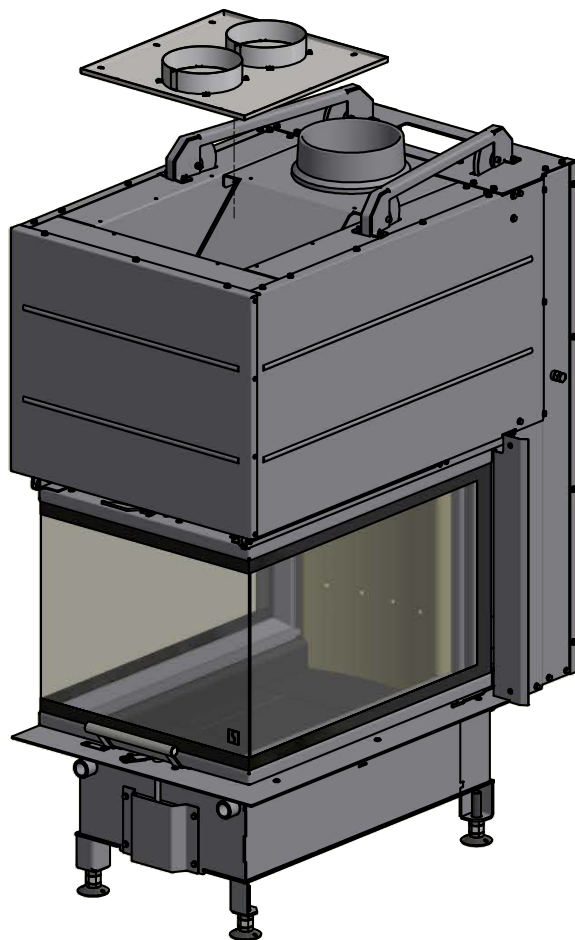
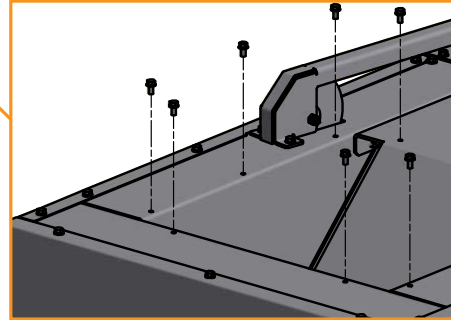

2

Place the heat shield on top of the stove and fasten it with the screws

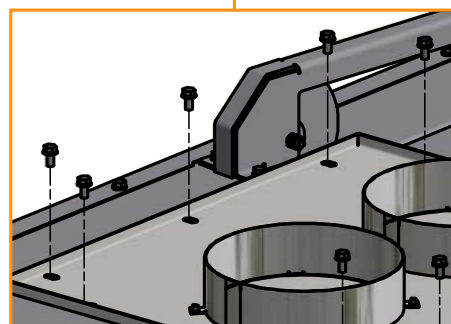
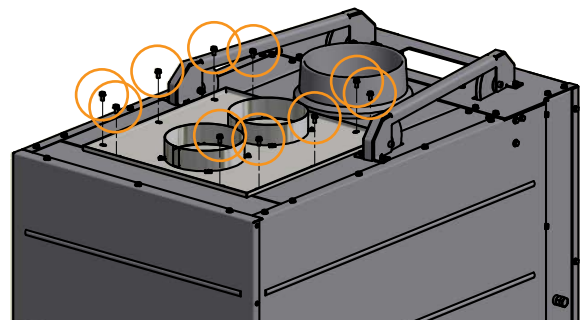

MOUNTING OF THE HEAT SHIELDS/CONVECTION COVERS (ACCESSORY)

The cover plate in the front must be removed, when you build the stove into a flammable wall.

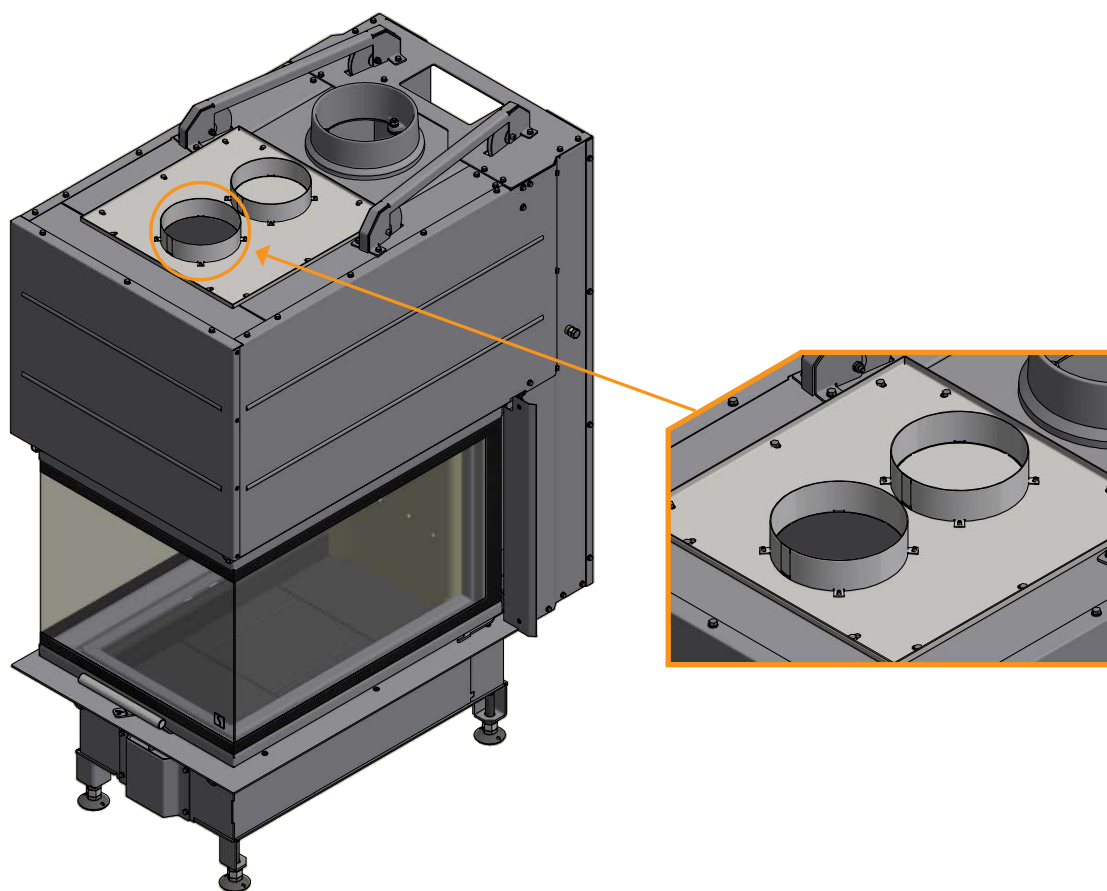

FRAMES (ACCESSORY)

Scan 5005 FRL Item nr. 50054930

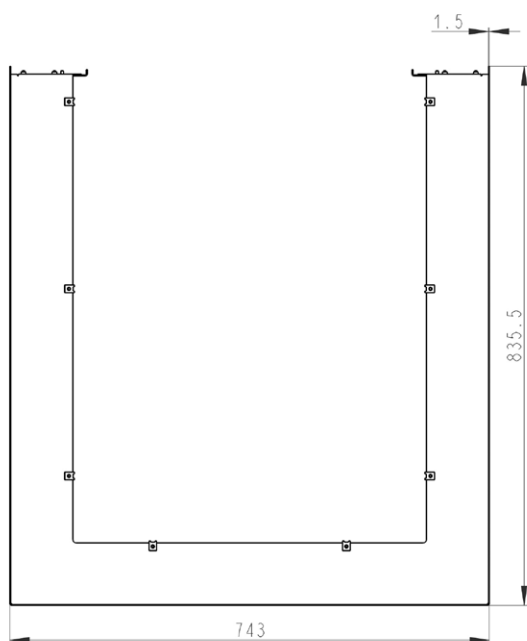
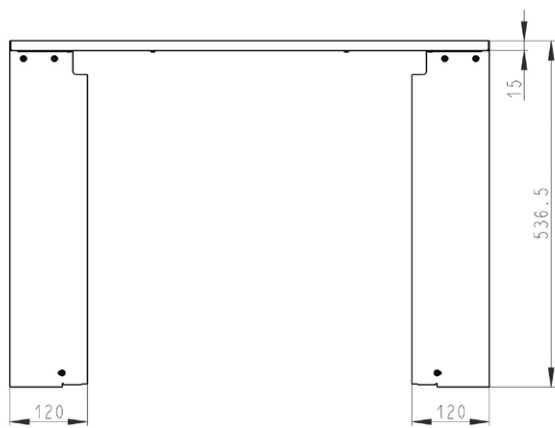
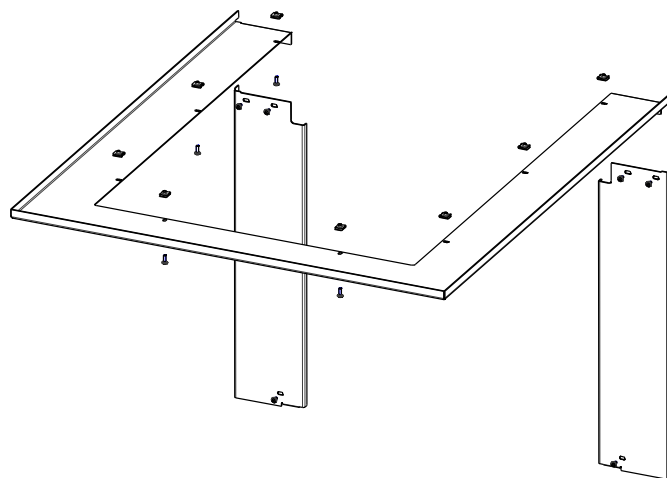

FRAMES (ACCESSORY)

Scan 5005 FRL Item nr. 50054931

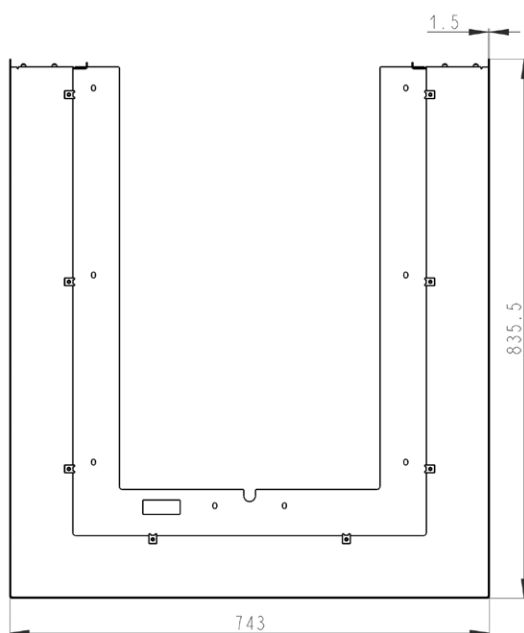
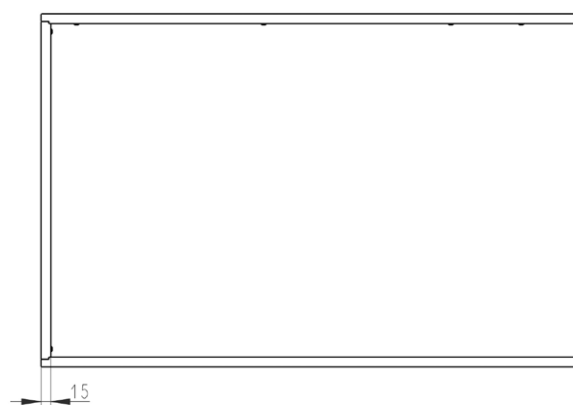
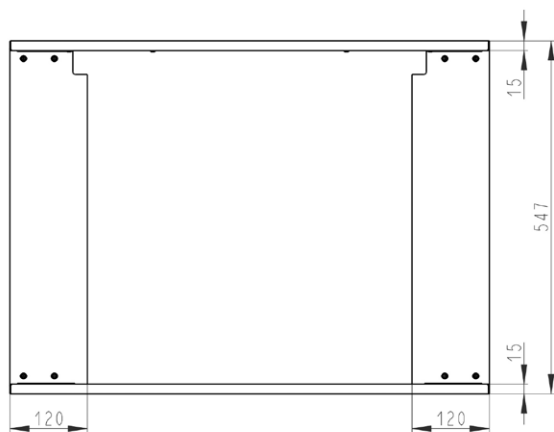
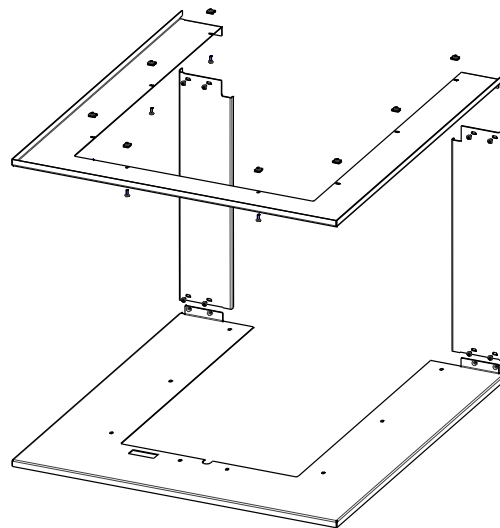

FRAMES (ACCESSORY)

Scan 5005 FRL Item nr. 50054932

Only for Scan 5005 FRL with support construction.

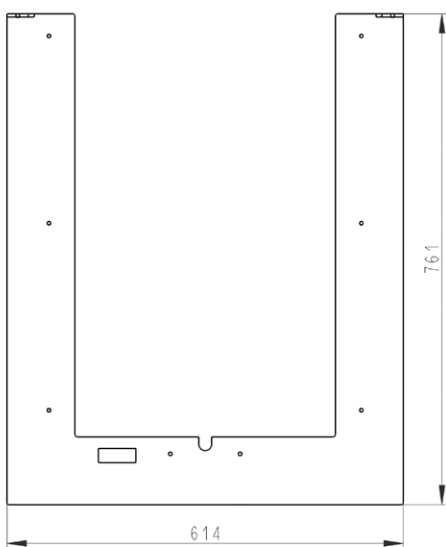
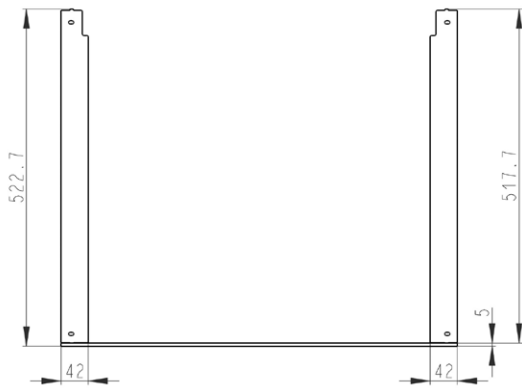
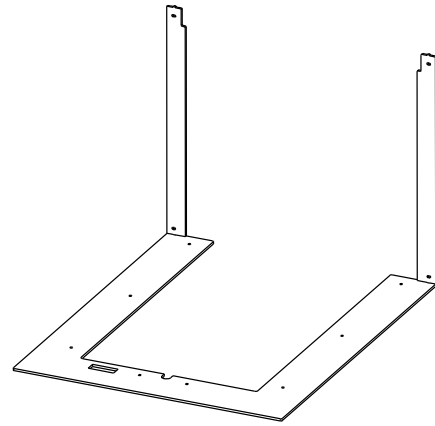

FRAMES (ACCESSORY)

Scan 5005 FRL Item nr. 50054933

Only for Scan 5005 FRL with support construction.

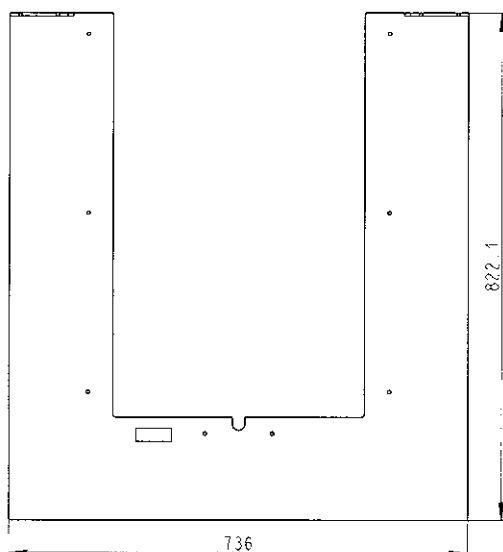
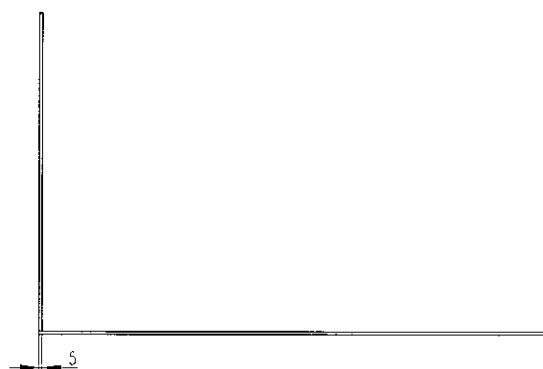
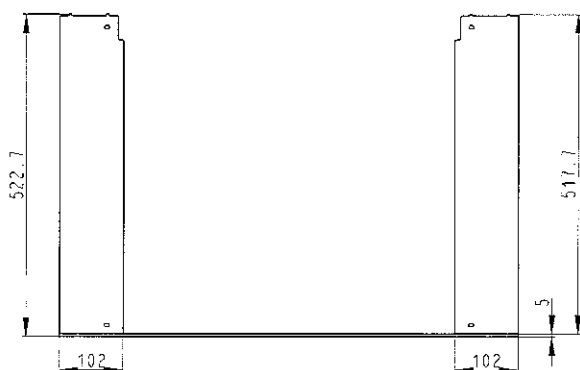
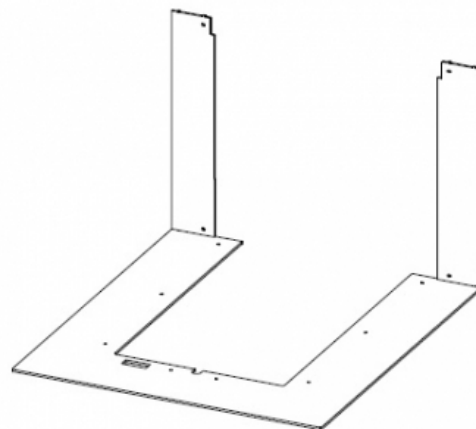

CONVECTION AIR

The covering must contain holes for convection air. Convection means that there is an air circulation ensuring that the heat is equally distributed in the room. It is important the demands concerning convection areas are observed.

■ Min. area for ingoing convection air: 500 cm²

■ Min. area for outgoing convection air: 750 cm²

If there is not enough convection air, the covering may be damaged.

Convection air grids are available as an accessory.

MOUNTING OF CONVECTION GRATE (ACCESSORY)

1

Cut a hole in the wall according to the indicated measures

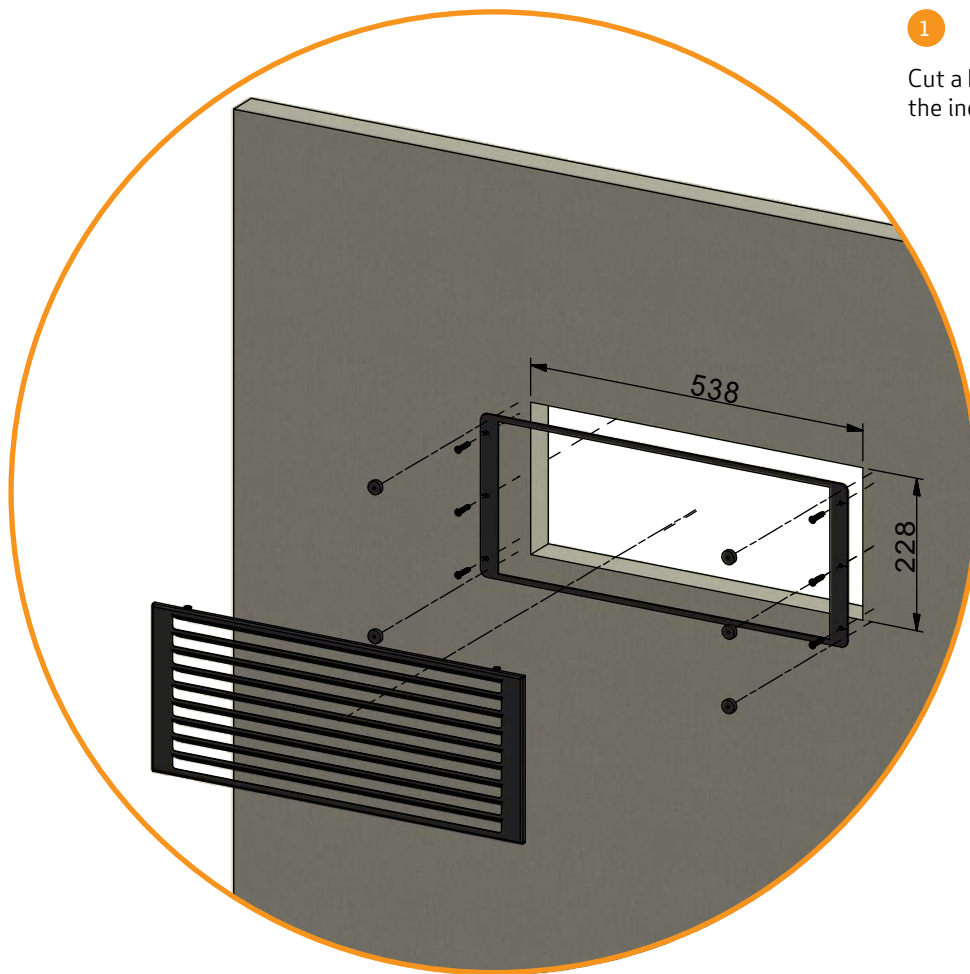

2

Fasten the metal frame with the six screws. Then mount the six magnets on the screws and place the convection grate on the magnets

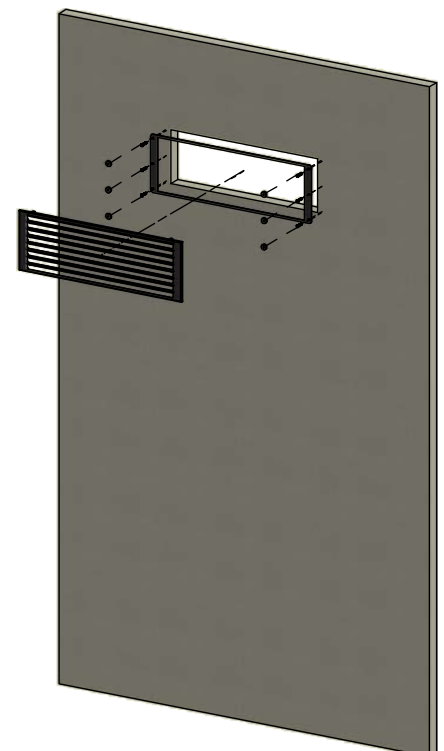

DETACHABLE HANDLE (ACCESSORY)

You can buy a detachable handle as an accessory.

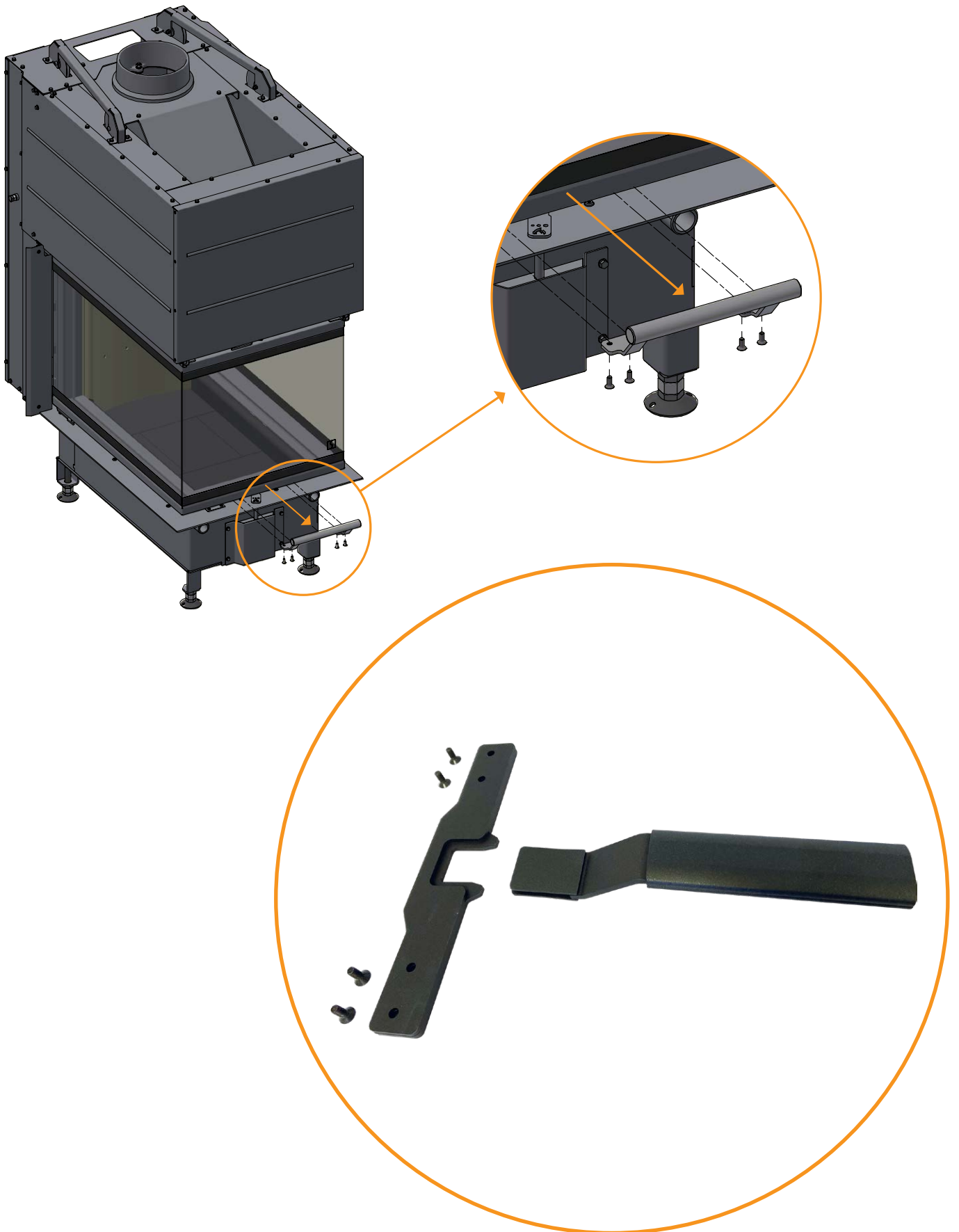

ASH CONTAINER WITH GRATE (ACCESSORY)

You can buy an ash container kit with grate as an accessory.

- The ash container must not become too full and must therefore be emptied at regular intervals
- Never empty ashes into a flammable container. Ashes can contain glowing embers long after you finish operating the stove



INSTRUCTIONS FOR USE

BAFFLE PLATES

The baffle plates are located in the upper part of the combustion chamber. The plates hold back smoke, making sure it stays inside the combustion chamber for a longer time before escaping through the chimney. This reduces the flue gas temperature as the gases have more time to dissipate heat to the stove.

The baffle plates must be removed for sweeping; see "Maintenance". Note that the baffle plates are made of porous, ceramic material, and are liable to break easily. You should therefore handle them with care.

The baffle plates are subject to wear and tear and not covered by the warranty.

COMBUSTION AIR

The combustion is regulated with the air damper. Combustion air is pre-heated and fed indirectly to the fire. The combustion air flow determines the heat output from your built-in stove. At the same time, the air flow cleans the glass pane to prevent build-up of soot. If there is a soot formation on the glass, this is often due to the fact that the combustion air is turned too much down.

When lighting the fire, the combustion air should be fully open.

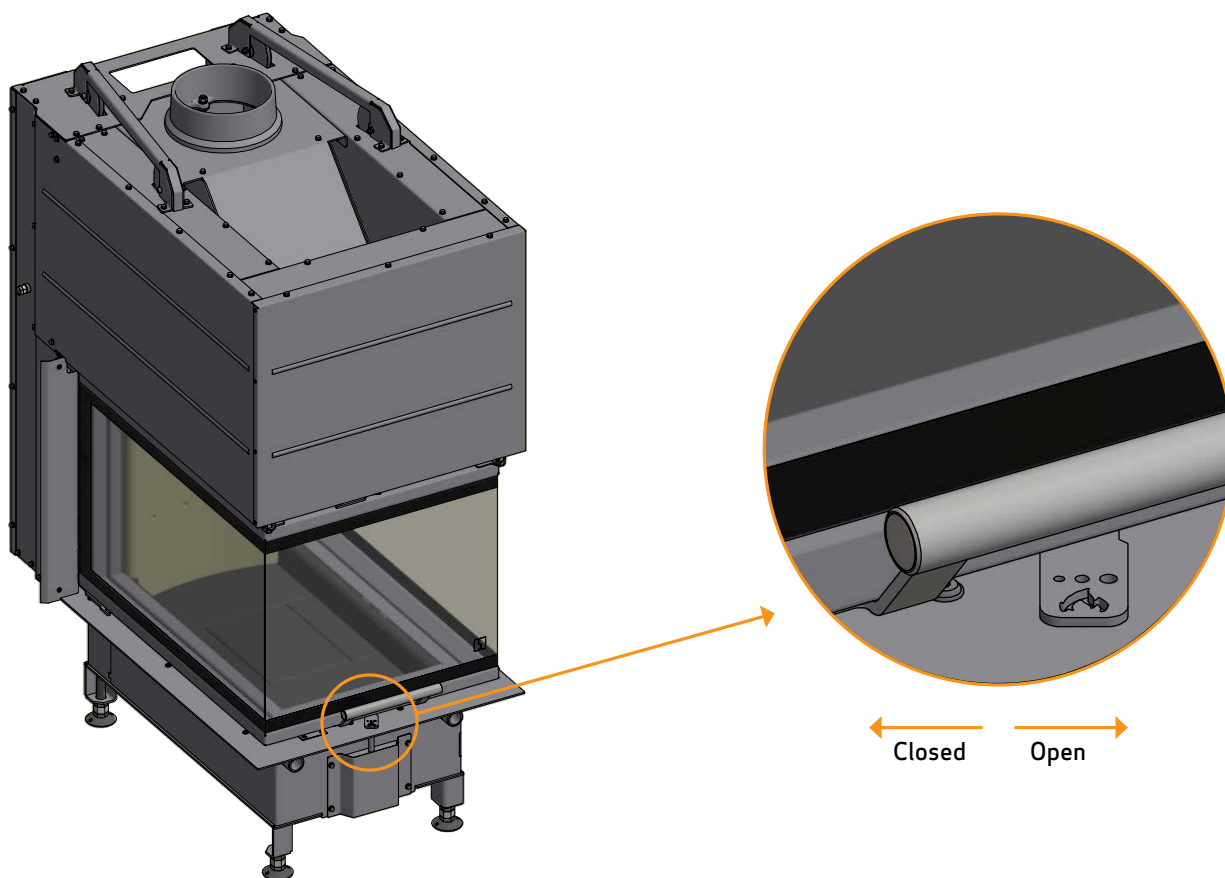

INSTRUCTIONS FOR HEATING

ENVIRONMENTALLY-FRIENDLY FIRING

Avoid turning down your woodburning-stove to the point where no flames are visible from the wood, as this leads to poor combustion and low efficiency. The gases released from the wood will not be burnt off due to the low temperature in the combustion chamber. Some of the gases will condense in the stove and flue system as soot, and this could lead to your chimney catching fire at a later point. The residual smoke which exits the chimney will pollute the surrounding area and cause an unpleasant smell.

LIGHTING

We recommend the use of fire lighters, or similar products. Using fire lighters helps light the wood more quickly and keeps the combustion process clean.

NOTE: Never use liquid lighting fuels!

The combustion chamber lining may turn black when the fire is lit. It will burn clear again the next time wood is added.

NOTE!
See our video
about correct firing



"TOP DOWN" LIGHTING

"Top down" lighting is a more environmentally friendly way of lighting the fire and helps to keep the glass area as clean as possible.

Do as follows for a correct "top down" lighting:

- 4 pieces of wood approx. 30-40 cm long with a weight of approx. 0.5-0.8 kg per piece.
 - 12-20 thin pieces of firewood of about 30-40 cm in length, with a total weight of approx. 1 kg.
 - 3-4 fire lighters
- 1 Place the pieces of wood, firewood and fire lighters in the combustion chamber as shown below
 - 2 Set the combustion air control to maximum for 20-30 minutes (See "Instructions for use")
 - 3 When the large pieces of wood have caught fire, you can adjust the combustion air to the desired level

NOTE: The wood must not cover the bottom entirely and must never be placed higher than the indication for max. load (This does not apply at a cold start) (See Maintenance).



Place the fire lighters
between the upper sticks

CONTINUOUS OPERATION

It is important to obtain as high a temperature as possible in the combustion chamber. This results in best possible use of the stove and fuel, as well as achieving clean combustion. In this way you will avoid build-up of soot on the combustion chamber lining and glass pane. During operation, you should not see any smoke; just a movement in the air that indicates combustion is in progress.

- After completing the lighting phase, you should have a good layer of embers in the stove; you can then start operation of it properly
- Add 3-4 pieces of wood at a time: they should be about 30-50 cm long - total weight of 2,2-3 kg

NOTE: The wood must catch fire quickly. This is why we recommend setting the combustion air flow fully open. Operating the stove at too low a temperature and with too little the combustion air can lead to gases igniting, which can damage the stove.

- When adding wood, always open the glass door carefully to prevent smoke escaping. Keep the door closed during the whole combustion phase
- Never add wood, while the fire is burning nicely

WARNING ABOUT OVER-FIRING

If the stove is continuously fired with larger amounts of wood than recommended and/or receives too much air, this can cause a heavy heat development liable to damage both stove and the surrounding walls. We therefore recommend that you always observe the max. recommended amount of fuel (See under "Technical Data").

USING THE STOVE IN VARIOUS WEATHER CONDITIONS

The way the wind affects the chimney can have a big impact on how your stove reacts under various wind loads; you may need to adjust the airflow to achieve good combustion. Fitting a damper in the flue pipe may also help, as it will allow you to regulate the draught under changing wind loads.

Fog and mist can also have a big impact on chimney draught; you may need to use other settings for the combustion air to achieve good combustion.

FIRING IN THE SPRING OR AUTUMN

In the spring/autumn transition period, where there is less need for heating, we recommend you light the stove "top down" once, perhaps adding just two pieces of wood to ensure that the combustion chamber lining burns clean again.

THE FUNCTION OF THE CHIMNEY

The chimney is the wood-burning stove's motor; its performance determines how well your stove will work. The draught in the chimney creates negative pressure in the wood-burning stove. The negative pressure draws the smoke out of the stove and takes in air through the combustion air damper to fuel the combustion process. Combustion air is also used for the air wash system that keeps the window clear of soot.

The draught in the chimney is created by the difference in temperature inside and outside the chimney. The higher temperature difference, the better draught. This is why it is important that the chimney reaches operating temperature before you reduce the damper settings to restrict combustion in the stove (a brickwork chimney will take longer to reach operating temperature than a steel chimney). It is very important that the operating temperature is reached as quickly as possible on days when the draught in the chimney is poor due to unfavorable wind and weather conditions. You need to get a few flames going as quickly as possible. Chop the wood extra thin; use an extra fire lighter etc.

- After longer periods without use, you must check the chimney flue for blockages
- You can connect several units to the same chimney. You should however first check the relevant regulations in this respect

CHIMNEY FIRE

In the event of a chimney fire, keep the stove door and dampers on the stove closed. In an emergency, call the fire service.

- We recommend that you get a chimney sweep to check the chimney before using the stove again

GENERAL NOTES

PLEASE NOTE! Parts of the wood-burning stove, especially the outer surfaces, become hot during use. Due care should be exercised.

- Wear a glove when handling the stove
- Never empty ashes into a flammable container. Ashes can contain glowing embers long after you finish operating the stove
- Keep the combustion chamber closed except during ignition, refuelling and removal of residue material to prevent fume spillage
- Keep the air intake and output holes free from any accidental blockage while the stove is in use
- When the stove is not in use you can close the dampers to avoid a draught through the stove
- If the stove has not been used for some time, you should check the flue passageways for potential blockages before relighting
- We advise you strongly not to use the stove over night. The stove is not suited for this purpose

NOTE: Never place flammable material in the radiation zone of the stove!

HANDLING OF THE FUEL

SELECTING WOOD/FUEL

You can use any type of wood as fuel. However harder woods, such as beech or ash, are generally better for heating, as they burn more evenly and create less ash. Other woods, such as maple, birch and spruce, are excellent alternatives.

PREPARATION

The best fuel is obtained where the tree has been felled and the wood sawn and split before May 1st. Remember to cut the wood to match the size of the combustion chamber. We recommend a diameter of 6-10 cm. The length should be about 6 cm shorter than that of the combustion chamber to leave enough space for air to circulate. If the diameter of the wood is greater than the above, it should be split down its length. Wood that has been split dries faster.

STORING

You need to store the sawn and split wood in a dry place for 1-2 years before it will be dry enough to burn. Wood dries faster if you stack it in an airy place. Before using it, it is a good idea to store the wood for a few days at room temperature. Remember that wood absorbs moisture from the air during autumn and winter.

MOISTURE

To avoid problematic impact on the environment and to ensure optimum operating economy, the wood should be perfectly dry before it can be used as fuel. If you use wood that is too damp, most of the heat it produces will be used up in evaporating the water. The stove will accordingly not increase in temperature, nor emit heat to the room as a result. This is obviously poor economy, and it will cause soot build-up on the glass pane, in the stove and in the chimney. Operation using moist wood also pollutes the environment.

- Maximum wood moisture content should not exceed 20%. A moisture content of 15-18% will deliver best efficiency
- An easy way of checking wood moisture content is to knock the ends of the two pieces of wood together. If the wood is moist, the sound will be slightly muffled
- It is a good idea to take the wood into the house a day before it is to be used

USE OF THE FOLLOWING AS FUEL IS ILLEGAL

NOTE: It is absolutely prohibited to fire with painted, pressure impregnated or glued wood, or sea driftwood.

NOTE: Never use gasoline, gasoline-type lantern fuel, kerosene, charcoal lighter fluid, ethyl alcohol or similar liquids to start or "reignite" a fire in the stove. Keep all such liquids well away from the stove while it is in use.

NOTE: Nor should you ever burn chipboard, plastics, waste or treated paper. These contain substances that are hazardous to human health, to the environment, your stove, and your chimney.

In short - make sure you only use proper wood.

CALORIFIC VALUE OF THE WOOD

The various woods have different calorific values. In other words, for certain species of wood, you will need to use a greater quantity to achieve the same heating performance. This Instruction Manual assumes that you will be using beech, which has a very high calorific value and is also the easiest wood to get hold on. If you use oak or beech as fuel, you need to bear in mind that these wood types have a greater calorific value than for example birch. To avoid any risk of damage to the stove, you should therefore make sure to use less fuel in these cases.

Wood types	kg Drywood/m ³	Compared to beech
Hornbeam	640	110%
Beech/Oak	580	100%
Ash	570	98%
Maple	540	93%
Birch	510	88%
Pine	480	83%
Fir	390	67%
Poplar	380	65%

MAINTENANCE

SWEEPING THE CHIMNEY AND CLEANING THE STOVE

Follow national and local regulations for sweeping the chimney. We recommend having the stove cleaned regularly by a chimney sweep.

Before cleaning the stove and sweeping the chimney, the baffle plates must be removed.

NOTE: All service and repair must be done, when the stove is cold.

CHECKING THE STOVE

Scan A/S recommends that you check your stove thoroughly after sweeping/cleaning. Check all visible surfaces for cracks. Check that all joints are tight and that the gaskets are correctly seated. Worn or deformed gaskets should be replaced.

SERVICING

We recommend that the stove is thoroughly serviced at least every two years by a qualified fitter. Remember only to use original spare parts.

The service should include the following:

- Lubricate hinges using copper grease
- Check the gaskets. Replace any that are broken or have turned hard
- Check the combustion chamber lining and the grate
- Check heat-insulating materials

COMBUSTION CHAMBER LINING

The combustion chamber lining is not covered by the warranty.

The lining consists of the following parts:

- 11 combustion chamber plates (1-2) ■ 3 fittings for baffle plates (3) ■ 3 baffle plates (4-6)

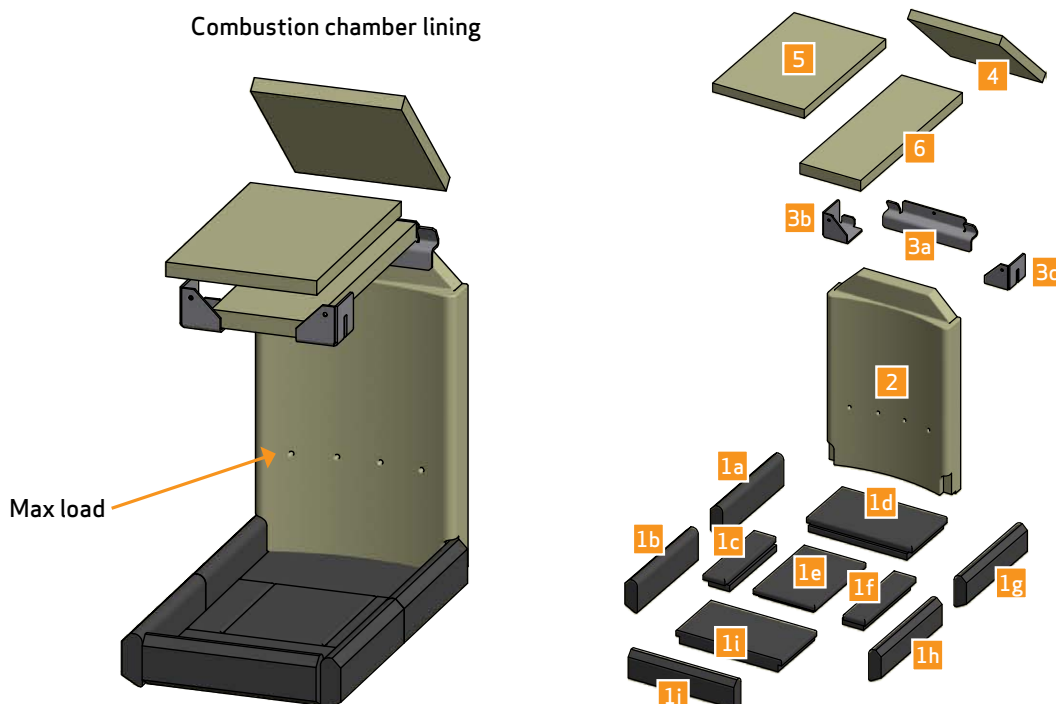

REPLACEMENT OF THE COMBUSTION CHAMBER LINING

Place the combustion chamber plate #1 in the bottom

1

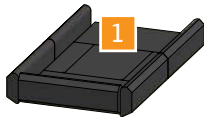

Place the combustion chamber plate #2

2

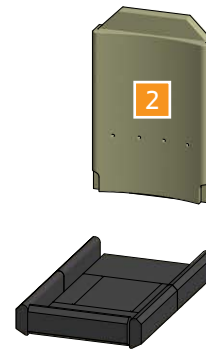

Place the upper baffle plates #4 and #5

3

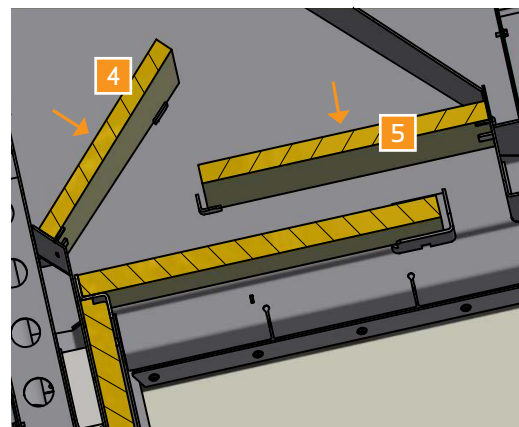
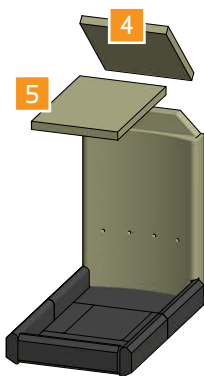

Place baffle fitting #3a on the edge of plate #2. Place baffle fittings #3b and #3c on the inside of the burn chamber. Then place the lower baffle plate #6

4

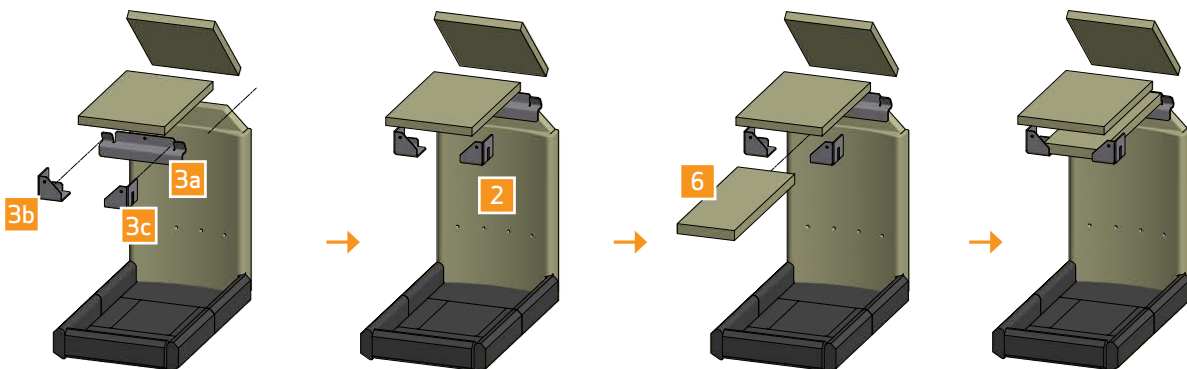

GASKETS

All stoves have seals made of ceramic material fitted to the stove, the door and/or the glass. These seals are subject to wear and tear and must be replaced when necessary.

Gaskets are not covered by the warranty.

PAINTED SURFACES

Clean your built-in stove by wiping it down with a dry, lint-free cloth.

DISPOSAL OF STOVE PARTS

Steel/cast iron	Send for recycling
Glass	Dispose of as ceramic waste
Combustion chamber lining	Vermiculite and chamotte are not recyclable. Dispose of as waste
Baffle plates	Vermiculite and chamotte are not recyclable. Dispose of as waste
Gaskets	Dispose of as waste

CLEANING THE GLASS

Our stoves are designed to prevent serious soot build-up on the glass. The best way to achieve this is to make sure you have a good supply of combustion air. It is also very important that the wood is dry and the chimney correctly dimensioned.

Even if you operate the stove in accordance with our instructions, a slight film of soot may still accumulate on the glass. You can easily remove this film by wiping the glass down with a dry cloth and then with a cloth dampened with glass cleaner.

- Please note that the glass cleaner is not to get into contact with the gaskets, as this can discolour the glass permanently
- The glass cleaner must not come into contact with the painted surfaces, as these can be damaged.

In order to be able to clean the glass on the inside, you must first pull out the glass frame.

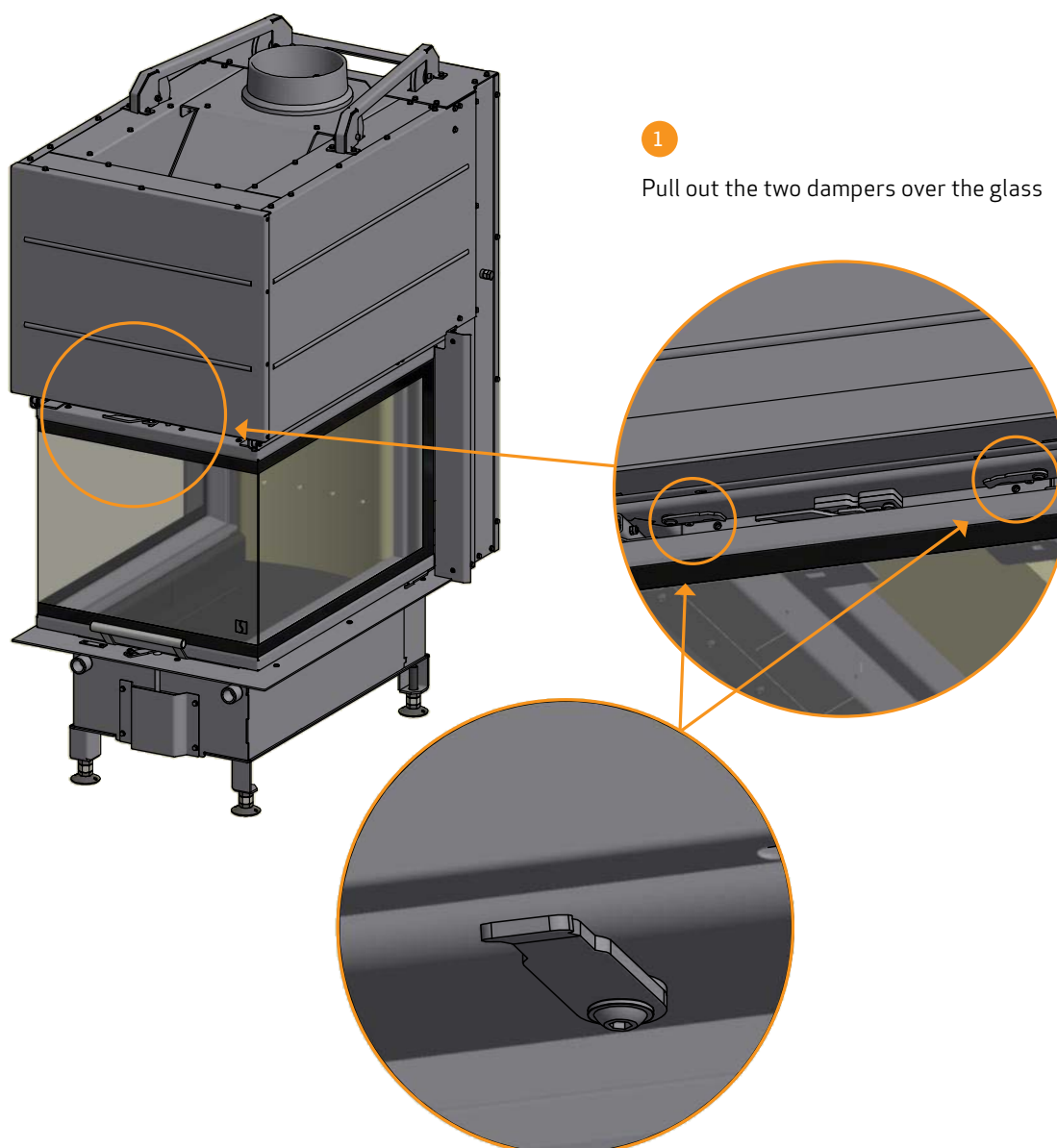

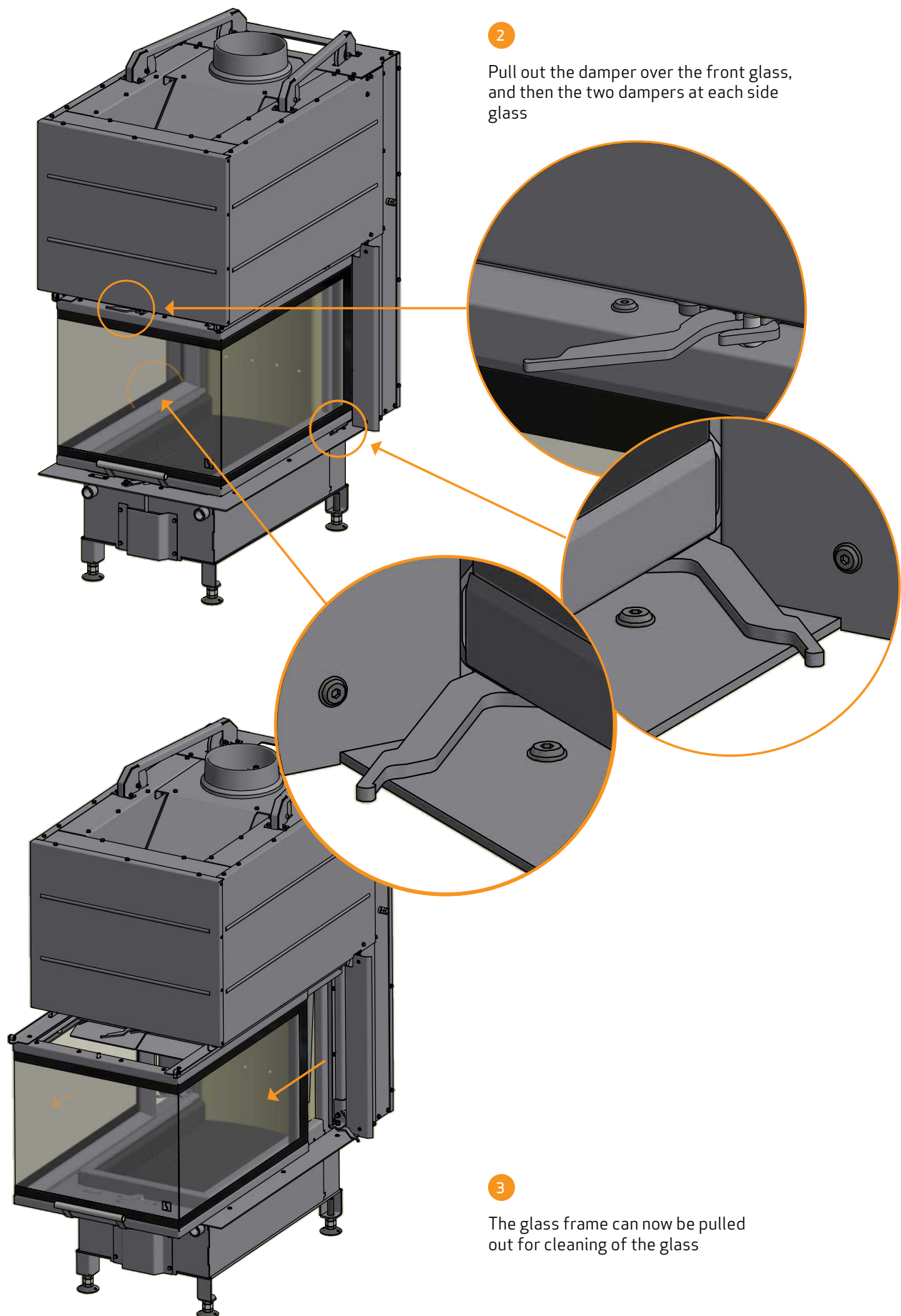

2

Pull out the damper over the front glass, and then the two dampers at each side glass

3

The glass frame can now be pulled out for cleaning of the glass

TROUBLESHOOTING

SMOKE ESCAPING

- Damp wood
- Chimney is not properly dimensioned for the stove
- Is the chimney the right height for its surroundings?
- At rear outlet, check that the flue pipe does not obstruct the chimney draught
- Chimney not drawing properly
- Check if the smoke gas pipe/chimney are blocked
- Vacuum in room
- The door is opened before the embers have burned down sufficiently

WOOD BURNING TOO QUICKLY

- The air valves are set incorrectly
- Inferior firewood (waste wood, pallets etc.)
- The baffle plates is incorrectly mounted or missing
- Chimney too large

SOOT BUILD-UP ON GLASS

- Incorrect secondary airflow setting
- Damp wood
- Inferior firewood (waste wood, pallets etc.)
- Vacuum in room
- Excessive primary air
- Wood pieces too large on lighting
- Chimney not drawing sufficiently

WHITE SHADOW ON THE INSIDE OF THE GLASS

- Over-firing (See "Instructions for heating")
- Vacuum in the room
- Too much primary air

EXCESSIVE SOOT BUILD-UP IN CHIMNEY

- Poor burning (more air required)
- Damp wood

THE SURFACE OF THE BUILT-IN STOVE IS TURNING GREY

- Overheating (see instructions for heating)

POOR HEATING PERFORMANCE OF BUILT-IN STOVE

- Damp wood
- Inferior wood quality with low fuel value
- Not enough wood
- Baffle plates are not fitted correctly

SMELL AND SOUND OF THE BUILT-IN STOVE

- The lacquer on the built-in stove hardens, when you use the built-in stove for the first time; this can cause an odour. Open a window or a door for ventilation and make sure that the built-in stove is heated up sufficiently to avoid odours later.
- When heating up and cooling down, the built-in stove may make some clicking noises. These are due to the huge temperature differences to which the material is exposed and do not indicate any product defects.

WARRANTY

All wood-fired Scan products are made of high-quality materials and subject to strict quality controls before leaving the factory. We give a warranty of 5 years on manufacturing errors or defects.

You must quote your stove's product registration number when you contact us or your authorized Scan dealer with a warranty claim.

The warranty covers all parts which in the opinion of Scan A/S require repair or replacement due to manufacturing or construction error

The warranty applies to the original purchaser of the product only, and is not transferable (except on prior sale).

The warranty covers only damage caused by manufacturing or construction errors.

THE FOLLOWING PARTS ARE NOT COVERED BY THE WARRANTY

- Wear and tear parts, such as the combustion chamber liners, baffle plates, riddling grate, glass, and seals (except for defects which were present on delivery)
- Defects caused by external chemical and physical influences during transportation, storage and assembly, or at a later time.
- Soot build-up caused by poor chimney draught, damp wood, or improper use
- Costs of additional heating in connection with a repair
- Transport costs
- Costs for setting up, removing the wood stove

THIS WARRANTY IS VOID

- In case of incorrect installation (the installer is responsible for observing and complying with legal requirements and local bylaws, along with this Instructions manual for the wood-burning stove and accessories)
- In case of improper use, and/or use of prohibited fuels, non-original spares (see this instructions manual)
- If the product registration number of the stove has been removed or damaged
- In case of repairs that do not comply with our instructions or instructions by an authorized Scan dealer
- In case of any manipulation of the original state of this Scan product or its accessories. Any unauthorized modification of the stove may not be carried out
- This warranty is only valid in the country to which this Scan product was originally supplied

Always use original replacement parts, or parts recommended by the manufacturer.

Product registration number

Quote this number at all enquiries